*Australian Military Small
Arms Ammunition Production
1888 - 2003.*

David A Mayne CPEng, MIE Aust, FRMIT.

**First Published by the Author in September 2003.
This is revision 1 - February 2004**

Table of Contents.

Pre Federation

The Colonies	2
Major F.T.Sargood.....	3
An offer from Greenwood & Batley	6
Captain John Whitney.....	7
Victorian Colony commits to a Factory.....	10
CAC site chosen.....	11
A description of CAC factory	11
Production Commences	13
Planning for 303 Ammunition	18

Federation

CAC site expansion.	23
Site Expansion Details	25
Dependency of supply from Overseas	26
Mr. C.N.Hake.....	27
Mr. A.E.Leighton.....	30
Erection of CAC Rolling mills and Foundry	31
303 Charger Manufacture	32
A new Supply Contract for CAC	37

CAC Pre- WW1 Miscellaneous Ammunition.

.310 Cadet Ammunition.....	39
Aiming Tube Ammunition.....	42

World War 1 and Beyond.

Local Self sufficiency	45
Government considers purchase of CAC.....	47
The Government Leases the CAC Site.	48

The Munitions Development Programme.

Commonwealth Reviews CAC	53
Nucleus Production.....	55
Surplus British Munitions Plant.....	57
The Munitions Supply Board.....	58
Government Munition Laboratories Established	60
Munitions Development Plan	62
Gun Ammunition Factory	66
Full ownership of CAC	67
Delayed Quality Problems.	68
Commercial Work.....	69
Australia moves toward War	71

The Wartime SAA factories

The first Upgrade at Footscray	73
Hendon S.A. chosen for new SAA plant.	76
Hendon Plant Duplicated	78
Reorganisation of the Munitions Supply Organisation.....	79
Munitions Ministry Created.....	80
Finsbury comes on line to supply Hendon.....	82
Rebuild of Footscray No 1 Plant.....	83
Plants planned for Rocklea and Welshpool	84
Site Plans for the WW2 SAA factories.....	90

The end of .303 production.

Closure of Wartime factories,	97
Limited post war production of .303 ammunition.	99
The last production runs of .303	101

Manufacture of 7.62 x 51 ammunition

Commencement of 7.62 production.....	103
The NATO symbol	104
Problems with pressure.	107
Commercial Ammunition and Components	109

The New 5.56 ammunition and the end of AFF.

Changing Government Plans	117
A New 5.56 Calibre and Weapons system.	118
Browning 50 calibre machine gun ammunition.....	121
Gulf and Western Plant.....	123
Footscray's Centenary	126
Australian Defence Industries.....	131
Site Closures	132
Problems with 5.56 Ammunition.....	134
ADI Benalla	136
Sale of ADI	140
History Repeats Itself.....	142

CAC Martini -Henry paper wrapped packets.

Images of Martini Henry Packets	145
---------------------------------------	-----

CAC .303 Mk.VI packets.

Images of CAC .303 Paper wrapped packets..... 153

.303 Mk.VII paper wrapped packets.

Images of .303 paper wrapped packets..... 161

CAC .303 Headstamps (1906-1926)

Photographs of .303 Headstamps (1900-1926)..... 165

Footscray .303 Headstamps 1927 -1962

Photographs of .303 ‘MF’ Headstamps (1927-1962) 175

Air Service Ammunition

CAC starts work on Airservice Ammunition 181

Air Service Ammunition Testing..... 183

The Test Method..... 185

Changes to Air Service Ammunition..... 188

Disintegrating Link Belts for Airservice Machine Guns. 189

Green ‘Red Label’ Ammunition 191

Standardisation of all Ammunition to AS requirements..... 191

.303 Incendiary Ammunition

Interest in Incendiary Manufacture..... 195

A dedicated WW2 incendiary factory	196
Incendiary deliveries	198
Test Firing of Incendiary Ammunition	200
Footscray exits the incendiary programme	201
Incendiary Headstamps	202

Armour piercing .303 Ammunition

MSB considers manufacture of AP ammunition.	205
--	-----

Tracer Ammunition.

Experimental Manufacture	209
The F3 Tracer.....	214

Blank Ammunition

.303 blank ammunition.	217
7.62 Plastic Blank cartridges	224
Full length Brass 7.62 blank	226

.303 Cartridges for propelling grenades and other devices.

Photographs of .303 Grenade Launching Cartridges.....	229
---	-----

7.62mm Cartridges for propelling grenades.

Photographs of 7.62mm grenade cartridges.	237
--	-----

Inert .303 Cartridges.

Dummy and Drill Cartridges243

Inert 7.62 & 5.56 Cartridges

Photographs of 7.62 & 5.56 Inert cartridges.....253

Ballistic Standard and Pressure Test (Proof) Cartridges

Ballistic Standard Ammunition261

Proof ammunition267

.380 Revolver, 9mm and .45 Auto Ammunition

.380 Revolver.....271

9MM ammunition.....275

.450 ACP ammunition280

.455 Webley ,.32 pistol, .22 Rimfire and .310 Cadet ammunition.

.455 Webley.....283

.320 Auto Pistol and .32 S&W Revolver Ammunition.288

.22 Rimfire Ammunition.....289

Jacketed .310 Cadet ammunition290

Foreword

The production of ammunition in Victoria in the 1890's was a significant event which ultimately led to major developments in Australia's Defence Industry and to Scientific Research and Development Capability. For those interested in examining the history of Military Small Arms Ammunition manufacture in Australia, available information is scattered and difficult to access. The purpose of this book therefore was to bring together for the first time the fragments of this history and to show how and why the industry evolved in the way that it did. I have borrowed heavily from the writings of J.K. Jensen and the annual reports of the Munition Supply Board. Some information has also been attributed to the periodic publications of the Australian Cartridge Collectors Association. The source of the material used in this book is acknowledged where applicable in appropriate footnotes. For the purposes of this book I have adopted the definition of small arms ammunition as being of maximum calibre 0.5" (12.7mm).

This book has been designed as an electronic publication which may be viewed with the freely distributed Adobe Acrobat Reader. Reader Version 5 or latter is required. By presenting the book in this form distribution is simplified. In addition graphics can contain much more detail than is available in a standard printed format. Many of the graphics will reveal their full detail when viewed at a high 'zoom' value, using the Adobe Acrobat Reader. Navigation through the book can be achieved by clicking on the page number in the Index or the section name in the Table of Contents. This will transport you directly to that section of the book.

Photographs have in some cases been enhanced to improve contrast or brightness using Adobe Photoshop, otherwise they represent actual specimens. The first nine chapters follow the evolution of ammunition manufacturing from the 1880's to the present time. The remaining chapters describe in more detail, the particular types of ammunition made over the years.

This project has been encouraged and assisted by Mr Darryl Page, Director of Ordnance , Australian Defence Industries and Mr Robert Morley former SAA section Manager at Footscray in the 90's and a current member of ADI's Management Team. Robert kindly provided information on the 5.56mm program and the establishment of the

Benalla facility. Thanks also to Mr John Evans, former Senior Defence Quality officer for proof reading this book.

Chapter 1 *Pre Federation*



FIGURE 1. *Ammunition Factory Footscray circa 1985*

Figure 1 shows a view of the Footscray Munitions Site Circa 1985 looking East toward the Melbourne City area with Gordon street. traversing left to right in the foreground, the Maribyrnong river at the rear and the Flemington Racecourse in the distance. Also visible is Jack's Magazine to the left and

the site of the original SAA factory at the centre of the scene on the river flats.

The Colonies

The original Australian settlement in the British Colony of New South Wales was followed progressively by additional Colonies in Tasmania, Western Australia, South Australia, Victoria and Queensland during the early nineteenth century. Each of these new colonies eventually gained self government in their own right. The British Government had accepted overall responsibility for the external defence of these colonies up until self government was achieved. In 1862 the British House of Commons passed a resolution which in effect said that on reaching self government the colonies should undertake the main responsibility of providing their own internal order and security and ought to assist in their own external defence. Accordingly, the last British troops were withdraw from the Australian colonies in 1870.

The Gold Rush in Victoria in the 1850's had lifted the population of that colony ahead of that of New South Wales for a period and each of these two colonies had populations greater than all of the others combined.

It is not surprising then that the push toward greater local defence self reliance revolved around these two colonies. Local military units in each colony were modeled on the British 'pattern' in both organisation and equipment although their appeared to be a considerable time lag between introduction of new military equipment and weapons in Britain and its flow on to the Australian colonies.

In 1866 Victoria, followed by South Australia and Tasmania, imposed high tariffs on imported goods in order to protect its own small industries and markets. New South Wales (and Queensland to a lesser extent) continued to stay with a free-trade policy. Throughout the 1870s and 1880s, the arguments over free trade versus protection divided the press, the political parties, and the colonies. This, together with the continuing jealousies among them, hindered any significant attempts at cooperation and possible union among the six colonies until the 1890s

Major F.T.Sargood

The first record of an interest in Australia in Munitions Production is dated January 17, 1882 when an enquiry was initiated in England by a Victorian officer of the Volunteers, Major F. T. Sargood, a principal of a local softgoods firm.

Major Sargood was a man of vision and imagination, always very keenly interested in defence matters; afterwards he became Minister for Defence, and was knighted for his services to the State. It was because of his initiative and drive that Victoria became the most advanced Colony in respect of Defence matters, and responsible for the origin of an Australian Navy and of Munitions Production.

Major Sargood's enquiry, which was directed to plant and materials needed for making the .45 in. Martini-Henry ammunition, was the beginning of a correspondence, under the lead of the Colony of Victoria, extending over several years. This involved the colonial governments in Australia, New Zealand, Fiji, and even Canada; with an occasional enquiry to England for information.¹

A key aspect of defence was the supply of small arms ammunition and as all ammunition supplies were at that time imported, certainty of supply was a real concern. After repeated failed attempts by the Colonies to reach agreement over the nature and location of a local factory to be established to supply the then current rifle calibre ammunition (577/450 Martini Henry), the Victorian Colonial Government

1. Reference 1 page 1

opted to go it alone with the establishment of a factory.

In 1885, the Victorian Colony sought expressions of interest from the British ammunition suppliers regarding establishment of a facility to supply the Martini Henry ammunition. It was prepared to provide a grant of land, an establishment incentive payment and exemption from certain import duties for the machinery which would need to be supplied. To encourage a response by potential suppliers, it was made known that the quantities of cartridges “consumes” required by Victoria during the year 1885-86 were:²

Ball cartridges	3,100,000
Blank cartridges	300,000
Carbine cartridges	200,000

and that it was expected that future consumption would be considerably greater.

The British suppliers generally felt that without the guaranteed orders from the other colonies, the Victorian demand did not justify a local factory.

2. Reference 2 page 2.

An offer from Greenwood & Batley

In July, 1887, the Victorian Government was advised that Greenwood & Batley Ltd. of Leeds, England - “manufacturers of all the Woolwich Arsenal cartridge machinery” - and certain other unnamed interests would form a private Company for the production in Victoria of small-arms ammunition “... and possibly later on of war stores generally”.

Further correspondence led to an invitation in February 1888 for Captain John Whitney of the Kynoch Company's ‘Colonial Ammunition Company ‘ in New Zealand to visit Victoria, to select a site for the proposed factory.

(The unnamed interests in addition to Messrs. Greenwood and Batley included Captain John Whitney and Sons of Auckland and Mr. W.T.Cartwright of Nottingham.)³

3. Reference 3 Munitions Supply Board Report for period 1/7/1926 to 30/6/1927 Pages 8-11

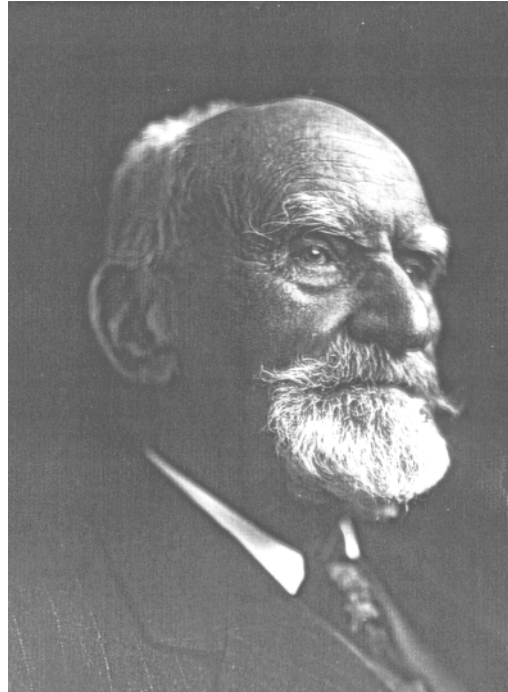

FIGURE 2. *Capt. John Whitney.*

Captain John Whitney.

John Whitney's letter to the Victorian Government on the 21st July 1887, offering to establish a plant in Victoria is reproduced below:-⁴

4. Reference 1 page 2

London. S.W.,
21st July, 1887.

Sir James Lorimer, K.C.M.G.,
8 Victoria Chambers,
Westminster.

Dear Sir,

Referring to the interview I had with you respecting the establishment of a small arms ammunition factory in the Colony of Victoria, I beg respectfully to make the following proposition, and shall be glad if you will lay the same before your Government.

As stated to you at our last meeting, I have been for some time engaged upon the manufacture of cartridges in Auckland for the New Zealand Government, and came to England a short time since to purchase additional machinery to increase production and prepare for the probable change in small arms. And whilst here have made arrangements with Messrs. Greenwood and Batley. "who make all the Woolwich Cartridge Machinery." and some one or two other gentlemen who have joined me in forming a small private Company for the production of small arms ammunition and possibly later on of war stores generally.

Seeing that the Australian Colonies are desirous also of establishing a factory for supply of S.A. Ammunition, our Company would be prepared to start a factory in Colony of Victoria, if we could receive the support of the Government. What we should ask would be, first, a subsidy from Government, which, considering the costliness of the machinery required and its installation, should not be less than £5000.

A site in favorable position for all Colonies, and from Military point of view, with favorable terms for the introduction into Colony of plant and necessary material and contract for say, ten years.

If such a proposition is likely to be favorably considered by your Government, I shall be glad upon my approaching return to New Zealand to go over to Melbourne and treat with you personally on the subject.

I am taking out all new plant of latest inventions and expect to have it working before next year.

I am,

Dear Sir,

Yours faithfully.

Signed JOHN WHITNEY.

Victorian Colony commits to a Factory

The Victorian Government reacted favorably to this approach and a further more detailed proposal was submitted in February 1888 and three weeks later the Victorian Government indicated it's acceptance. The 'company' had registered the "Colonial Ammunition Company" with the registrar of Joint Stock Companies in England and the Certificate of Incorporation was dated January 30th 1888. It should be noted that a company also called 'Colonial Ammunition Company' had been established in New Zealand in 1885. The Australian and New Zealand Colonial Ammunition Companies were separate legal entities even though a number of personnel such as John Whitney, had interests in both. . Part of the proposal was that the new factory would supply at least three million rounds per year for 25 years. An Indenture dated 28th May 1889 was prepared by the Victorian Government including the above requirement together with the provision of a grant of £5,000 and a lease of 5 acres of land on a peppercorn rental basis.

CAC site chosen

Before the Indenture was signed, the site for the Factory - on the Saltwater River at Footscray, 4 miles from Melbourne - was selected by Captain Whitney after consideration of sites on the Murray River and at Sydney. The latter consideration arose out of suggestions that a factory to serve all of the Colonies should be established at a central point, but the negotiations fell through. The chosen site was also half a mile from the then existing Victorian Government explosives magazine which also utilised the river for explosives transport. Part of the 'arrangement' was for the new ammunition plant to draw its gunpowder (black powder) from the Government on a repayment basis. An act of the Victorian Parliament (Act 1022 of 4th November 1889) ratified the agreement with the company.

A description of CAC factory

The following description of the Factory appeared in "The Illustrated Australian News" of 8th November, 1890. 'The Saltwater River gives cheap and convenient transport, and is therefore an essential feature in the selection of this

site, as compared with the inland sites so strongly advocated. A wharf has been built, carrying a crane and a store house, and a 2-foot tramway connects it with the factory. The Factory is constructed using timbered structures clad with galvanized iron and sitting on brick piers to elevate the floors about 2 feet above ground level. (D.M. possibly to provide some protection from the flooding of the river which occurred from time to time). Eight separate buildings were constructed to cover the various stages of the ammunition production the largest of which being the case shop measured some 167 feet long by 72 feet wide.' As was the practice of the day, machinery was driven centrally from a single 'engine' driving shafting mounted in the rafters from which drive belts were connected to the individual machines. The factory had a 100 horsepower steam powered engine for this purpose. The cartridge machinery had been purchased from Greenwood and Batley in England. The workforce consisted of about 200 being mostly juniors (some boys and about 150 girls)

Hand drawn illustrations that accompanied the above article gave sketches of :-

-a general view of the factory,

- women cutting brass foil for the cartridge cases
- a woman shaping the cartridge cases
- 'the automatic bullet machine'
- 'a heading machine'
- 'bullet canalluring machine'
- 'riveting machine'
- 'a wax wad machine', and
- a capping machine.

Production Commences

In July 1890 the factory was ready to commence production. It should be noted that the Victorian Colony's 'The Ammunition Factory Act 1889' (Act 1022/1889) required CAC to complete the factory and to deliver ammunition within 12 months from enacting this legislation on 4th November 1889.

The Martini-Henry ammunition undertaken at CAC was of the brass foil case body with steel head design and had a paper patched lead projectile as shown below. This design was approved in England as the Martini Henry Rolled Case Mark III in 1873. A drawn case variant was introduced in England in 1885 but CAC did not have the plant to produce

this type. Detail of the construction of the 'rolled case' variant is as follows:- The case is made of sheet brass of 0.004 inch in thickness, partially covered on the inner side with paper attached with cement. It also has a small band of 0.004 inch sheet brass attached to the inner side in such a way as that when the case is rolled up, it will be between the folds so as to prevent 'cutting' at the top of the base cup. There is a small hole punched in the case sheet so as the band can be seen to be in the correct position after forming. The brass sheet is assembled with brass base cups and a steel base disc which forms the rim. and inner paper annulus and a riveted primer arrangement hold the case together. The neck is closed down from .577 inch diameter to .45 inch to retain the bullet. The case is charged with 85 grains of blackpowder.



FIGURE 3. The rolled case Martini Henry Rifle cartridge.

On top of the charge is placed a glazeboard disc with a concave beeswax wad attached, after which two more glaze-

board wads are added. The bullet is secured by 'choking' the brass neck into the two bullet cannelures.

The bullet weight was 480 grains and the propellant was 85 grains of blackpowder.

The components of this assembly are shown in the following illustrations. (figures 3 & 4)

The CAC plant was still totally dependent on importation of metal strip and of primers from overseas.

After the commencement of production, difficulties and disputes arose between the Government and the Company as to the interpretation of various clauses of the Indenture, and to settle these a further agreement was signed on the 19th December, 1893. Manufacture of the 0.45" Martini Henry ammunition proceeded successfully with some exceptions. There was, for instance, the deputation of employees which waited on the Victorian Minister for Defence (Sir Frederick Sargood) in October 1892 to complain about the cessation of operations at the factory following the arrival in Australia of 1,000,000 rounds of ammunition ordered in England some time previously.

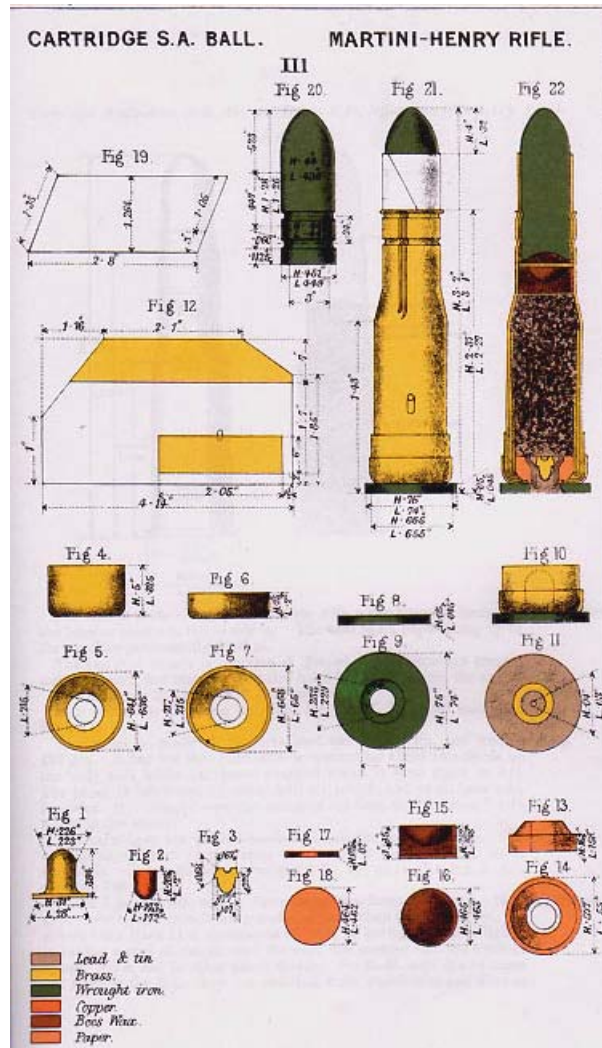

FIGURE 4. The component parts making up the rolled case

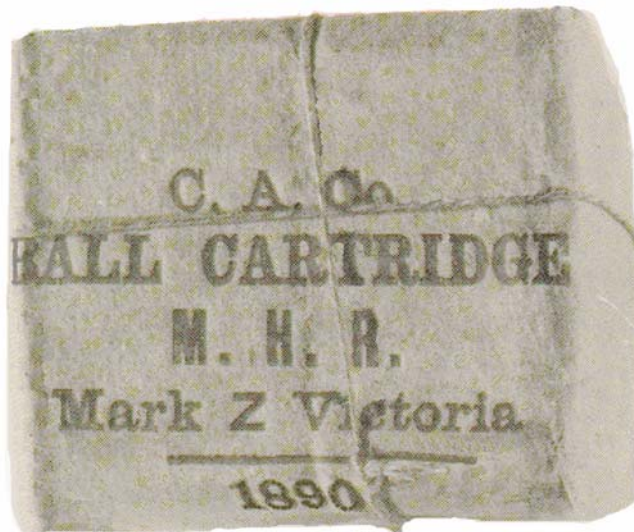

FIGURE 5. *Initial CAC Production in the form of a 1890 string tied paper wrapped bundle of 10 rounds of Martini Henry Rifle Cartridges made for the Colony of Victoria.*

/

A serious explosion occurred in a Finishing Room at the Factory on 23rd September, 1897 , destroying part of the Factory and killing 3 female employees. This incident was investigated by the Victorian Colony Chief Inspector of Explosives, Mr. Cecil Napier Hake. Hake arrived from England in 1890 and was an authority on explosives and on small arms ammunition in particular. He had co-authored the book “Smokeless Powder and its Influence on Gun

Construction” (J.A.Longridge London 1890) with W.Mac-nab.

The investigation found that CAC was lacking in it's safety procedures and corrective action was taken at the factory.

Planning for 303 Ammunition

During the 1890's considerable inter-colony friction existed over the use of the Melbourne factory to supply other than Victorian needs. The introduction of cordite loaded .303 calibre ammunition into British Service prompted New South Wales to agitate for a Government owned factory to be established to supply the new .303 requirements. At a Premier's Conference in March 1898, there was general agreement that NSW could proceed with this proposal, however the impending Federation of the Colonies stalled any further action in this regard. In any case the Victorian Government had already arranged for CAC to obtain the necessary new equipment to commence .303 manufacture and had not supported the NSW idea as its 25 year supply contract with CAC was still valid. At this time the Victorian requirement alone ran at 4 million rounds per year which was about 50% of the factory's expected annual output.

CAC's relationship with Greenwood and Batley in the UK resulted in initial .303 ammunition being supplied from GB in

Britain and repacked and labeled with CAC wrappers. This ammunition had either GB or CAC headstamps or was un-headstamped. It is reported that such packets of CAC Mark II .303 carried dates of 1898 through to 1900.⁵

The first locally made .303 ammunition (Mk. II ball) commenced into production in 1900 and the production of the Martini Henry ammunition was discontinued. The Mark II cartridge had a 215 grain cupronickel jacketed round nose projectile and a charge of 31 grains of cordite size 3 3/4 in 60 strands. A glazeboard wad was placed between the cordite charge and projectile.

The latest known surviving packet of CAC Martini Henry ammunition was dated 1901 and consisted of repacked English ammunition made at Eley Brothers Limited. Surviving CAC .303 Mark II ammunition in collections are found largely without headstamps although limited numbers may be found with head-stamps as shown later in this book. Based on advice from cartridge collectors it is likely that the headstamped Mark II rounds were not locally produced but supplied as part of imported bridging stocks supplied through CAC but obtained from other sources.

5. Reference 4 Journal No. 80 1999.

Mark II and Mark VI .303 packets dated 1904 exist in collections thereby indicating that the changeover from Mk. II to Mk. VI occurred during 1904. It is believed that all Mk. VI ammunition was head-stamped and in May 1906 the month and year of production was added to the headstamp.

The Mark VI round was externally identical to the Mark II, the difference being in the design of the bullet in which the bullet jacket was thinned at the nose to provide greater 'upset' on impact to enhance its 'stopping power'.



FIGURE 6. A 1903 Mark II ball 10 round paper wrapped string tied packet. See latter chapter for further examples.



FIGURE 7. The components of MK II, VI and VII rounds. From top the Mark II with cordite size 3 3/4 (usually about 60 strands) , centre the Mark VI also with cordite size 3 3/4 and lower Mk VII with the ‘thicker’ cordite MDT size 5/2 (usually 36-40 strands). Note the glazeboard wads and that the Mk II and Mk VI projectiles are not externally different.

Chapter 2: *Federation*

CAC site expansion.

On the 23rd April 1901 a lease to extend the CAC site from approximately 5 acres to 40 acres was approved by the Victorian Colony.

The following graphic is a reproduction of the 'extended plan lease' signed by John Whitney at the Crown Solicitors Office Melbourne.

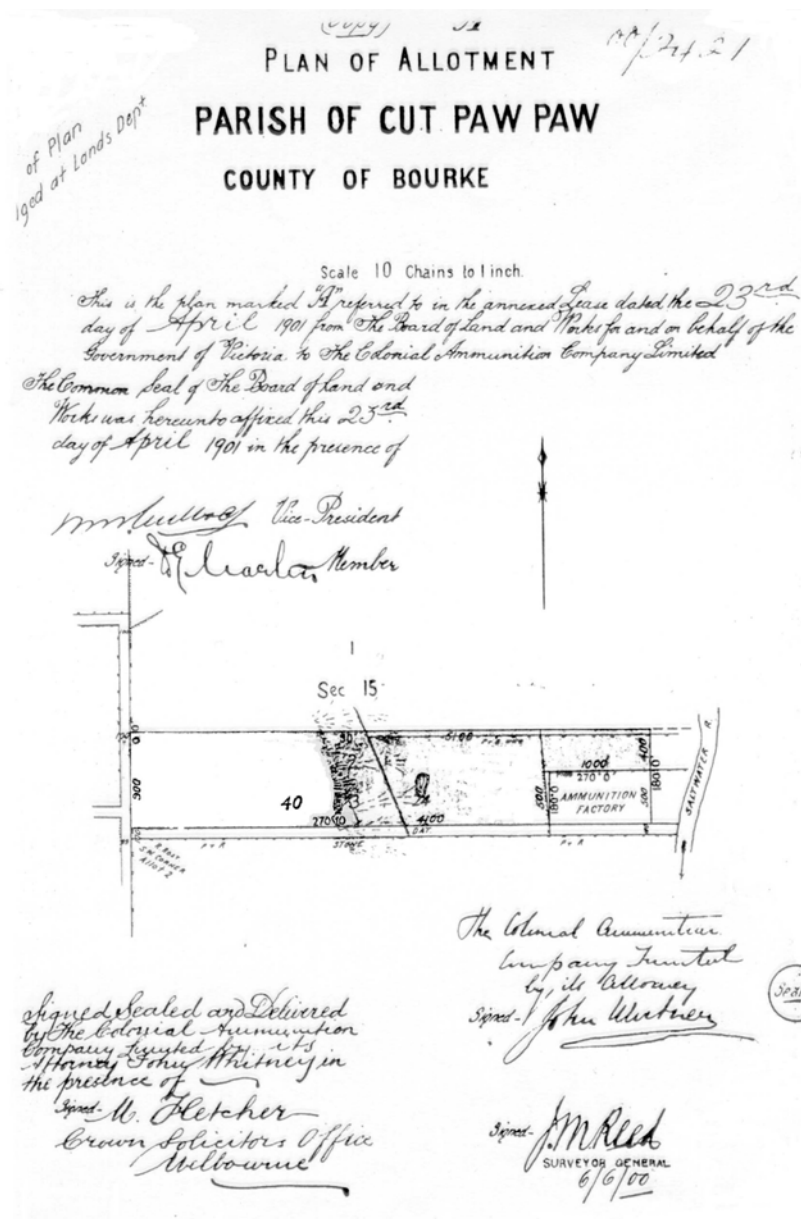

FIGURE 1. A copy of the 1901 'extended' lease for the Colonial Ammunition Company

Site Expansion Details

The original site of 5 acres was a rectangular site with about 100 metres of river frontage and depth extending due west approximately 260 metres. The new lease gave CAC approximately 180 metres of river frontage and a depth of 1100 metres extending due west across the river flat and up the valley wall to the edge of Gordon street.

The reason for the additional land was to provide extensions associated with the change to cordite propellant, and to cater for the increased demand generated by the South African War and the great expansion of Rifle Clubs.

With Federation of the Colonies, defence became a Commonwealth Government responsibility consequently the land leased to CAC and an amount of adjoining land was transferred to Commonwealth control.

After Federation, the new Federal Secretary of Defence accepted in principal the idea of a Federal Government owned Ammunition plant from which all Defence demands would be supplied. However due to the capital expenditure required and the operating costs involved he deferred any

action since there were already adequate facilities operating at CAC Footscray.

Dependency of supply from Overseas

The dependency of CAC on overseas supplied brass and cupronickel cups from which they produced cartridge cases and projectiles and also the importation of primer caps and cordite caused concern within the Defence Department. In 1902 the new Federal Government approved the continued association with CAC provided that it maintained a reserve of metal components equivalent to 10 million rounds of ammunition and that it undertook to establish primer cap manufacturing capability. By June 1906, the Commonwealth had agreed to maintain the reserve stocks of metal as a Government responsibility with the Company having the right to draw on these stocks from time to time, if necessary, but subject to replacement as soon as new stocks could be procured.

Mr. C.N.Hake.

The new Federal Defence Department began planning to expand the local defence capability. In April, 1907, Mr. C. N. Hake, on loan to the Commonwealth from the Victorian Government, was sent to England to investigate Cordite manufacture. In 1908, Engineer-Commander W. Clarkson (later Sir William Clarkson, Third Naval Member), who was visiting England about the same time on Naval matters, and who later arranged contracts for the first destroyers of the Royal Australian Navy, was requested to investigate the possible production of rifles in Australia.

Hake's cordite investigations in England indicated that deterioration of this material under the conditions of elevated temperature and humidity, such as could be expected in Australia, was a significant factor. The manufacture of cordite in Australia under Government control resulted from Hake's recommendation that the product manufactured by the Royal Gunpowder Factory at Waltham Abbey be preferred to offerings by commercial firms. He attributed the superiority of its product to good quality control, which prevented the inclusion of impurities which hastened deterioration at elevated temperature¹

Another of Hake's recommendations concerning the setting up of explosives manufacture in Australia and accepted by the Commonwealth Government was the need to create an independent authority for the inspection and maintenance of the quality of explosive materials. He left the Victorian Government to be appointed (Commonwealth) Inspector of Explosives in 1907 and continued to act as Chemical Adviser to the Government. Marcus Bell was appointed as his assistant and succeeded him in the position when Hake retired in 1911

Probably the first attempt at scientific inquiry into munitions operational problems occurred under Hake's guidance when, with Dr. Thomas Lyle, Professor of Natural Philosophy at Melbourne University, they carried out experiments to prove his theory that the bursting of 0.303 inch magazine rifles was not caused by defective composition of ammunition from the Colonial Ammunition Company. Their examination showed that 'double bulleting' was possible with the automatic machines at CAC and that closer quality control could eliminate the problem.

1. Reference 10 pages 901-905

As considerable stocks of explosives were held throughout Australia - mostly for military purposes - Hake set up a testing laboratory at Victoria Barracks to check the state of preservation of these stocks, some of which had been held for over ten years. He reported that only ten per cent had deteriorated beyond acceptable limits and would have to be destroyed. These were held mostly in Queensland.



FIGURE 2. The original Victoria Barracks Laboratory Building

Hake's reports on cordite manufacture had been accepted by the Commonwealth and as a result the Maribyrnong Racecourse site was selected for the new factory. Mr. A. E. Leighton, then Assistant Manager of the Indian Government Cordite Factory at Aravankadu , had been nominated by Mr. Hake to be Manager.

Mr. A.E.Leighton

Mr. Leighton arrived in Australia in February, 1909, and commenced work on the design of the new cordite factory.

In February, 1910, Leighton left for England to select the plant for the factory. Mr. N. K. S. Brodribb joined as Chemist in October, 1910, and he too left for England in March, 1910, for assistance to Mr. Leighton in respect of plant and for study of processes. This was the beginning of the Munitions organisation in Australia.



FIGURE 3. Arthur Edgar Leighton (1873-1961)

Towards the end of 1910, the buildings were proceeding at the Cordite Factory Maribyrnong (CFM), and soon after that the plant commenced arriving.

Erection of CAC Rolling mills and Foundry

At the Colonial Ammunition Company, in an Agreement gazetted on June 11, 1910, CAC undertook to erect metal-rolling mills on the Footscray site, together with the necessary brass foundry, both of which were brought into operation in 1912. This was done only after the Commonwealth Government agreed to CAC's request that it be given a 99 year tenure over the 40 acres of land described in the Victorian Government lease of 1901. CAC also undertook to provide machinery for the manufacture of caps and paper wads.

The Small Arms Factory at Lithgow commenced manufacturing in February, 1912, and was formally opened in June, 1912. At the opening function Mr. Leighton announced that the first batch of cordite had been produced at CFM. The production of Mercury fulminate for primer cap production at CFM commenced on the 22 July 1915. It was then possible to produce primers at CAC and these were available later in 1915.

303 Charger Manufacture

TABLE 1. .303 Ball Production at CAC versus Rifle and Charger Production at SAF

Financial Year	303 Ball produced at CAC	303 Rifles produced at SAF	303 chargers produced at SAF
1910-1911	15,062,000	nil	nil
1911-1912	20,788,000	nil	nil
1912-1913	30,737,000	40	1,785,352
1913-1914	28,143,000	4,760	2,687,692
1914-1915	53,533,000	13,786	2,502,004
1915-1916	61,600,000	30,460	8,009,000
1916-1917	97,470,000	23,960	9,319,412
1917-1918	37,449,000	23,251	7,345,270
1918-1919	19,076,000	42,129	5,455,098
1919-1920	16,540,000	25,570	7,411,714
1920-1921	10,639,000	20,420	1,748,480
1921-1922	22,854,000	14,440	nil
1922-1923	2,830,000	2,700	nil
1923-1924	2,830,000	3,320	nil

With commencement of operations at the Small Arms Factory Lithgow, that establishment was tasked with the manufacture of .303 chargers for supply to CAC. Lithgow made chargers carried the Mark No of the charger together with an indentifier in the form of an asterisk. These symbols were stamped into the side of the charger as can be seen in the following photograph. The quantities of rifles and chargers manufactured at

SAF and the corresponding quantities of ball ammunition made by CAC by year are given in the previous table² -

2. Reference 3 1924 Report pages 12 & 17 for figures 1913-1923 and Reference 4 Journal No 73 page 17 for figures 1910-1912



FIGURE 4. English Mark I and SAF Lithgow made Mark II,III and IV .303 Chargers

When considered with the advice that 303 Mk VI was offered from CAC in carton packed and wrapper packed form and that 303 Mk VII was offered as carton packed, bandolier packed or wrapper packed³ the above table would indicate that perhaps as much as 50% of deliveries were charger packed with an overproduction of chargers (stockpiled ?) from 1917 on.

Wrapper packed ammunition consisted of 10 rounds enclosed head to tail within a printed paper wrapper tied with string.



FIGURE 5. A Typical paper wrapped 10 round packet from CAC (1912)

3. Reference 3 1924 Report page 13.



FIGURE 6. Typical WW1 20 round packets of 303 'carton packed' and charger packed

Carton packed Mk VI and Mk VII .303 ammunition shown above consisted of a small cardboard box containing 20 rounds with paper interleaving and the packet enclosed with a black bitumen like tape. Charger packed ammunition used the same carton as just described but enclosed four chargers of 5 rounds packed alternatively nose to tail. Neither carton normally carried an external identifying label. In the illustration above a packet is shown with a label affixed some 20

years later when these 1920 'out of life' rounds were released to Rifle Clubs in 1941. The label is a 'disclaimer' by the Department of Army as to the serviceability of the ammunition. Bandolier packing consisted of a cloth 'belt' containing 50 rounds consisting of 5 pockets each containing 2 chargers of 5 rounds.

A new Supply Contract for CAC

The original 25 year supply agreement established by the Victorian Government with CAC expired on the 27th May 1915 however the Commonwealth Government delayed entering into a further agreement with CAC as the question of a Government owned factory had again arisen. It was eventually decided to propose a further 5 year supply agreement commencing from 1st July 1917 whereby the Commonwealth agreed to take a minimum supply of 40 million rounds annually. The price to be paid to CAC would be that paid by Britain to its suppliers plus an allowance for local manufacture. When this proposal was put before the Minister of Defence it was referred to the Board of Business Administration which re-examined the issues in detail and eventually came up with a new proposal acceptable to both the Govern-

ment and CAC, and which was duly signed by both parties. The agreement was for the supply of 40 million rounds per annum commencing on July 1st 1919. The pricing was changed to an arrangement calculated from actual costing figures with provision for a measure of profit to CAC.

Chapter 3: *CAC Pre- WW1 Miscellaneous
Ammunition.*

.310 Cadet Ammunition

In 1906 the Defence Department placed an order on CAC for the production of ammunition for the .310 Cadet Training Rifle which had been in use since about 1902. Ammunition had been previously supplied from Britain. CAC production deliveries commenced in 1909 and continued each year until 1913 when resources were fully allocated to wartime .303 production. Both Ball and Blank loadings were produced with cases stamped "CAC 310" although some unheadstamped blank cases may be encountered. A table indicating quanti-

ties and timing of CAC .310 ammunition production is given below¹.

TABLE 1. Pre WW1 .310 Cadet ammunition Production

Financial Year	Ball production	Blank Production
1910-1911	3,744,000	50,000
1911-1912	9,400,000	nil
1912-1913	9,500,000	4,250,000
1913-1914	13,225,000	1,775,000

The ball rounds had lead projectiles of 125 grains with a loading of 5.5 grains of Schultze² smokeless powder. The blank loading was 10 grains of Black powder.

-
1. Reference 4 Journal 73 page 18.
 2. Reference 4 Journal 58 page 5, but also referred to as Nitrokol by Munitions Supply Reports .



FIGURE 1. Above: A 1911 packet of .310 ball ammunition

FIGURE 2. Below: A 1911 packet of .310 Blank ammunition-note that the ball label was used with a rubber stamp "BLANK" imprinted across the front





FIGURE 3. Typical CAC 310 Cadet Blank and Ball loadings

Aiming Tube Ammunition

CAC also used its association with Greenwood and Batley to supply overseas sourced ammunition to the Defence Department and others. Aiming tube ammunition used in adapters in Military service rifles and in some early single shot Francotte Lever Action 'Cadet' Rifles is an example of this. Figure 5 shows a 1906 packet of the .297/.230 aiming tube ammunition carrying the Greenwood and Batley and CAC identifying Marks.

Aiming Tube Ammunition

These cartridges were supplied in 'long' and 'short' variations as shown.



FIGURE 4. .297/.230 short and long Aiming Tube Cartridges.

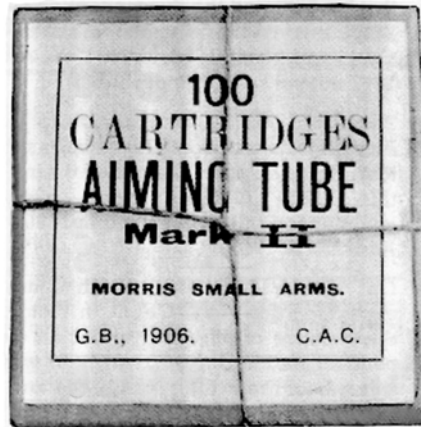

FIGURE 5. A typical packet of CAC supplied Aiming Tube cartridges made by Greenwood and Batley.

Chapter 4: *World War 1 and Beyond.*

Local Self sufficiency

With the introduction of locally made primers in 1915, the major components of CAC 303 ammunition were for the first time Australian made. It is interesting to note the changes in primer appearance in the 1915-1916 CAC rounds. Some examples are shown below. Some smaller diameter than standard primers were used in production in May-July 1915 marked rounds, while the standard diameter primers also continued to be used.

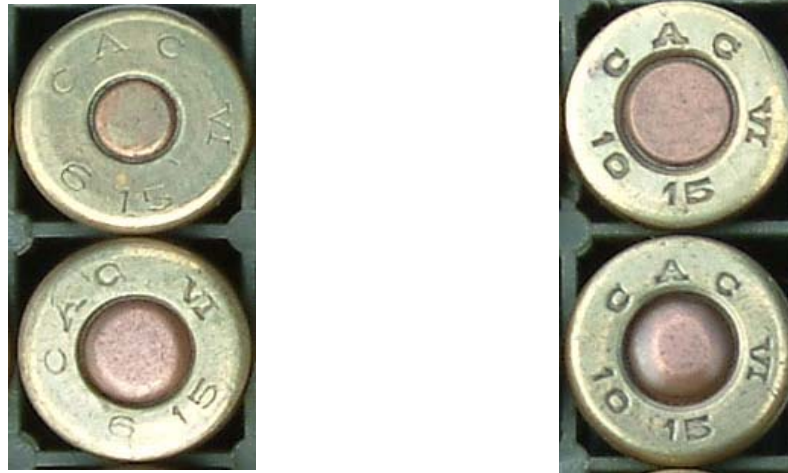

FIGURE 1. Left Small and normal primers of June 1915 and Right flat and normal primers of October 1915. The small primers may be found on May through July production. The flat primers appear from late 1915 to early 1916.

Later in the year, the primers took on a flattened appearance (local production phasing in?) but then settled down to a more rounded appearance but somewhat less than the pre 1915 heavily rounded imported form. 'Round-nose' Mark VI ammunition ceased production on January 1918 with the Mark VII rounds being introduced in February 1918. (see later chapter.). In addition to the .303 ball ammunition shown in Chapter 4 table 1, CAC manufactured quantities of Blank

and 'Dummy' rounds for training purposes during the WW1 period. These are included in the following table.

TABLE 1. .303 Blank and Dummy Production 1913 - 1926^a

Financial Year	.303 Blank	.303 Dummy
1913-1914	8,818,000	1050
1914-1915	5,000	195,000
1915-1916	865,000	1,620,000
1916-1917	nil	5,000
1917-1918	nil	7,150
1918-1919	nil	5,000
1919-1920	nil	5,000
1920-1921	nil	4,000
1921-1922	nil	14,000
1922-1923	nil	nil
1923-1924	nil	8,000 Drill
1924-1925	131,527	5,000 dummy 69,000 drill
1925-1926	nil	10,000 drill.

a. Reference 3 Annual Reports July 1926-June 1927 page 15 & July 1924-June 1925 page 12.

Government considers purchase of CAC

During August 1916, the question of purchase of the Company's works by the Government was again raised with the Company in the context of the planning then in hand for the establishment of a Central Arsenal, including a new Small-Arms Ammunition Factory. The Company proposed that the business could be taken over for £350,000, plus all new capi-

tal issued after 31st December 1915; all capital expenditure since that date; all stores and materials in hand and on order; and partly-manufactured goods at cost price plus 100 per cent on the wages for establishment charges. Cabinet, however, decided that no action would be taken at that time and the Company was so informed on August 23, 1916. The Arsenal concept was destined to be abandoned at the end of the 1914-18 War

The Government Leases the CAC Site.

The proposed nationalisation of the Factory was revived again during the initial stages of the post-War recession when the Company informed the Government that, because of the paucity of orders for 0.303" rifle ammunition, it would be unable to maintain production without appropriate Government assistance. As the continued operation of the factory was regarded as an important element of the national Defence policy, the Commonwealth agreed to lease it from the Company and took over responsibility for its activities as from January 1, 1921 under a 7-year lease, at an annual rental of £20,000 plus rates, insurance and the like and with

the Company's Manager (G.A. Cartright) continuing to manage the works for the Commonwealth.



FIGURE 2. :The CAC bullet shop circa 1915





FIGURE 3. The 3 packets above show the changes in marking as the Government took over running of the plant . A 1920 dated CAC packet , a 1920 CAC label overstamped as a 1921 S.A.A.F packet and a 1921 MF marked packet . The cartridges themselves did not acquire the MF mark until 1926. (see later chapter)



Mr G.Cartwright Manager 1913-1927

The leasing arrangement was, however, terminated in 1927 when the Commonwealth purchased the factory as a going concern for £150,000 to be paid in installments spread over 10 years, including interest of 5 per cent per annum on the outstanding balance as from January 1st, 1927 - a total payment of £191,152.12, 0d.

FIGURE 4. Mr. G.Cartwright Factory manager 1913-1927

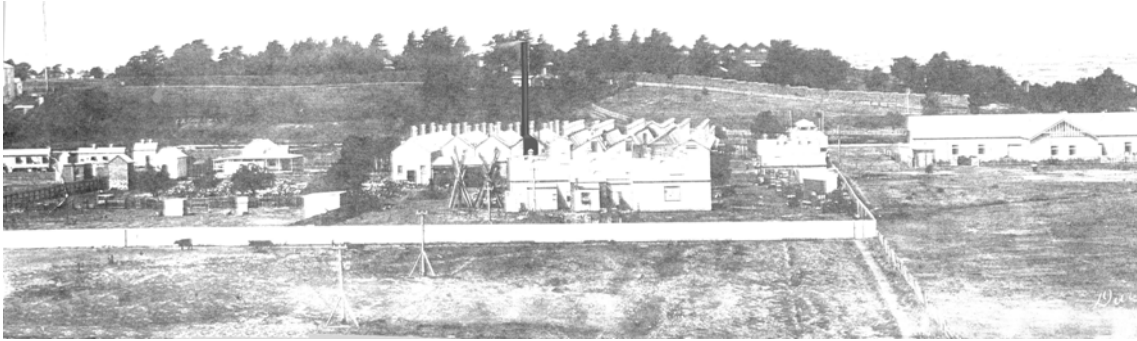

FIGURE 5. The CAC factory circa 1921 viewed from between the upper and lower factories looking in an easterly direction . The hill at the rear is the boundary of Flemington Racecourse. The river is obscured by the buildings. The Canteen is shown at the extreme right , the shooting houses are at the extreme left and the main SAA shop is in the centre behind the chimney.

Chapter 5: *The Munitions Development Programme.*

Commonwealth Reviews CAC

A survey of the CAC site was conducted and Drawing W1103 dated 21/10/1921 was prepared to record the layout at that time. Parts of that drawing have been reproduced below to depict the CAC buildings on the river flat area ('the lower factory') and the Cap factory and the Rolling Mill and foundry ('the upper factory') on the Gordon street frontage.

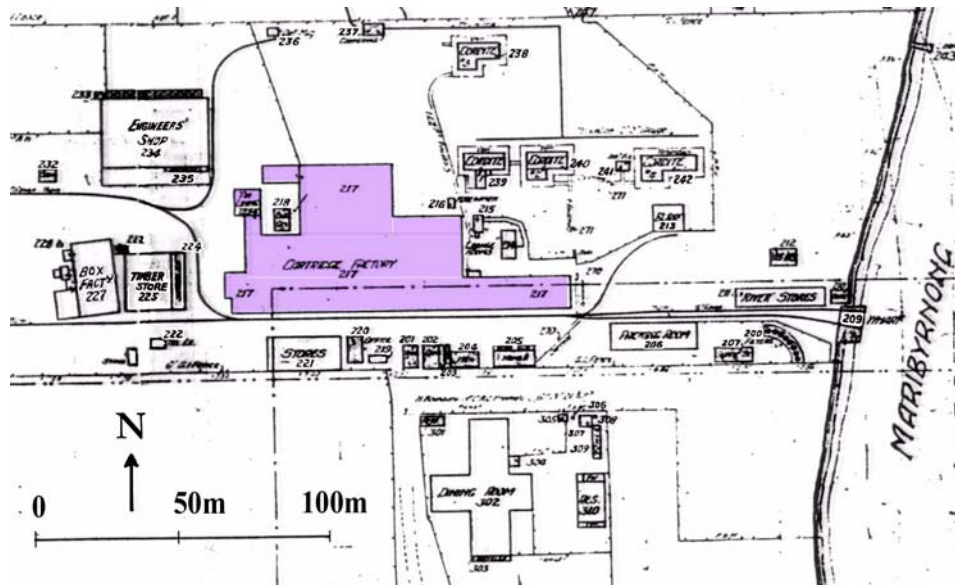

FIGURE 1. A Plan view of the lower CAC Factory area showing the main Cartridge Shop colored for clarity. The wharf on the River is still evident. Cordite loading buildings are adjacent to the Cartridge Shop to the north. Firing Ranges are not in view but are immediately north of this area with shooting from near the river bank to the west with a stop butt against the valley wall. In the lower portion of the Plan outside the fence line is the factory Canteen. The cartridge shop shown measured some 300 ft. x 150 ft. indicating that the original case shop constructed in 1890 which was 167 ft. x 72ft no longer existed and most likely was replaced as part of the expansion for .303 production in the early 1900's or during the expansions of WW1.

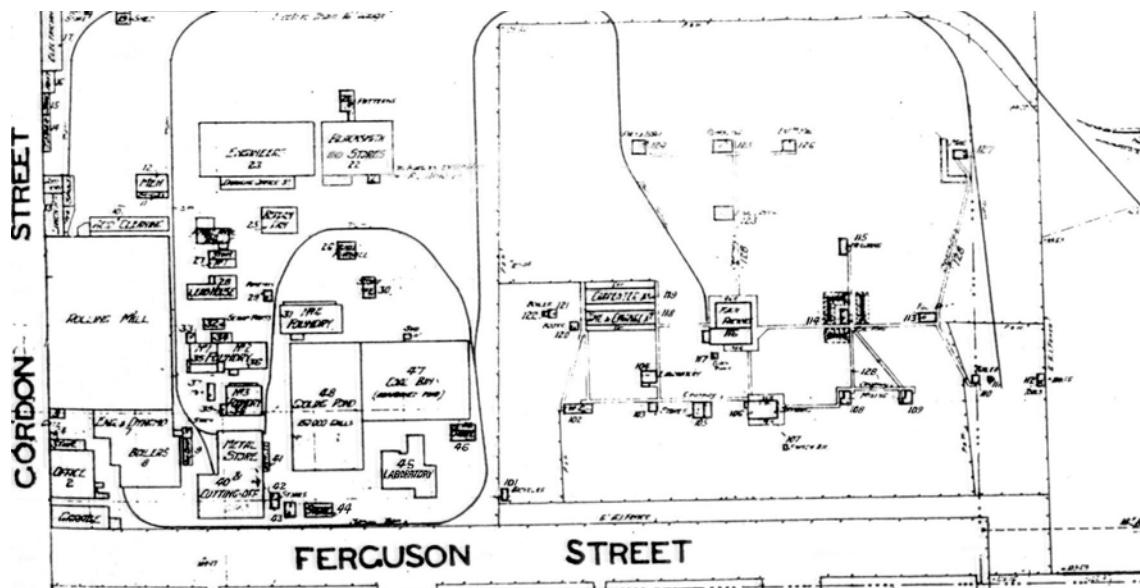

FIGURE 2. The 'Top CAC Factory' comprising a Foundry and Rolling Mill (left) and a Cap Factory (right). Ferguson Street is now called Owen Street. Also shown is a narrow gauge tramway network which also extends to the lower factory. In the early 1920's the Federal Government commenced construction of a Gun Ammunition Factory on the 'CAC' northern boundary. The Gun Ammunition factory had its own Foundry and Rolling Mill. The CAC site was merged with the Gun Ammunition Site in 1928 under the Gun Ammunition Factory Manager J.H.Wrigley.

Nucleus Production

The funds available for maintaining the Government Factories then operating were limited in the Government's 1922-23 Estimates to £192,200. The policy of "nucleus production", which had to be introduced during this depression period to ensure retention of essential skills, directly affected the Foot-

scray works in that the ammunition production programme there largely determined the quantity of cordite to be produced at the Government Cordite Factory.

It was consequently decided that the nucleus output would be 3,000,000 rounds annually of 0.303" ammunition. This decision involved the retrenchment over a two year period of 633 of the 810 persons employed at June 30, 1921, when production was at a depressed annual rate of approximately 10,000,000. The Military Board agreed to this reduced programme on the condition that the Factory would be capable of attaining full production again within six weeks. This low production rate together with the rifle cordite on hand at the Cordite Factory equivalent to some 10-12 years of supply at this rate resulted in investigations being initiated as to the shelf life of bulk cordite and a stop on production of further rifle cordite at CFM as from June 1922. Some small quantity of revolver cordite for the Webley .455 service revolver ammunition was in production. At June 1924 the Cordite Factory still held on hand 260,000 lb. of small arms cordite sufficient for approximately 40 million rounds of .303 ammunition.

Surplus British Munitions Plant

Several years earlier, in March, 1919, the Australian Minister for Defence, then Sir George Pearce, arrived in England in connection with the completion of demobilisation arrangements with the British Government.

Being very much concerned with the large amount of plant becoming available in England, Mr. J.K.Jensen, stationed in Australia's London Office, was sending forward various proposals to Australia and doing everything possible to direct attention to the possibilities of acquiring cheaply, large quantities of good munitions plant. Mr. Leighton was doing what he could in Australia, but it was only Senator Pearce who realised the possibilities, and he took the matter up with the Minister for Munitions, Lord Inverforth, and finally with Mr. Winston Churchill - at that time Secretary of State for the Dominions. At his arrangement, the British Government offered Australia £300,000 worth of munitions plant at a rebate of 50 per cent. on the cash valuation; thus it was to cost actually £150,000. J.K.Jensen spun the offer out to £340,000 and got 1600 machines of highest quality - a great many absolutely new, and even those second-hand were mostly in first-class condition. They ranged from a 1500-ton

forging press down to a wood lathe. They were bought at surplus market prices, and so there were occasions of machines being purchased at ridiculous prices -£30 for a machine costing £500 or £600 - and it is safe to say that on the then current market prices the value would be £1,500,000 for the £170,000 expended.

In July 1919 the London office was closed, and the returning men provided Australia with all the knowledge and the plant necessary to establish production of almost every type of munitions and even aeroplanes and engines of the types current at the time. The Office even sent out the information then available regarding metal aeroplanes, and while in due time the munitions plants were put into operation, nothing, unfortunately, was done about aeroplanes.

The Munitions Supply Board

Mr. Leighton was equally busy in Australia, his first step being to prepare a comprehensive report based upon his war experience, and upon the technical information acquired in London. The report was presented on May 27, 1919, one result being abandonment of the Central Arsenal Scheme in favour of a policy of decentralisation. When he returned to Australia

in 1919 Leighton expressed with some force his conviction that the location of an Arsenal near Canberra, remote from a labour and shipping centre, was unsound and that existing facilities should be developed and a balanced industrial complex formed with scientific support under a Munitions Supply Board. The Government accepted his ideas, the Arsenal Project as conceived was abandoned,

Despite the abandonment of the Central Arsenal proposal, Leighton retained the position of 'chairman, Board of Management, Government Factories,' and continued to approve drawings carrying the Commonwealth Arsenal title block into early 1921.

A. Leighton
GENERAL MANAGER
DATE: 16.9.20.

RIFLE, M. L. E., MARK I* C, BARREL.									
DRAWN	DATE	TRACED	DATE	APPD	DATE	APPD	COMMONWEALTH ARSENAL		
CHECKED	DATE	CHECKED	DATE	APPD	DATE	APPD			
CABINET	TUBE	DRAWER	SCALE	APPD	DATE		3165	X-787	

FIGURE 3. An example of the Commonwealth Arsenal title block of Drawing X-785 approved by Leighton on 16/9/1920 is shown. Leightons signature as 'General Manager' is at the left

Leighton's report contained a complete scheme for a Munitions Supply Organisation, but it was launched at a time of doubt and indecision, the prevalent belief of both Parliament and the people being that there would be no more wars. Disarmament was being discussed as public policy and opinion was decidedly adverse to Defence expenditure. Since such thought persisted for probably 15 years, the uphill effort of the Munitions Supply Board to develop the Australian Munitions capability has to be applauded.

Government Muniton Laboratories Established

One section of Leighton's report which received favorable attention was the emphasis placed upon the need for scientific control of manufacturing, both in the quality of materials and the accuracy of measurement. Money was voted for the establishment of extensive laboratories modeled upon the National Physical Laboratory in England and the Bureau of Standards at Washington, and Australia should be very grateful to Mr. Leighton for the foresight which brought them into being. The laboratory was initially staffed with personnel from the Victoria Barracks Laboratory and with the young technologists who had been trained in England. Its official

functions, which reflected five years of planning by Marcus Bell (Hake's successor) , were to maintain standards of manufacture and supply, to promote by research the production of defence supplies from Australian raw materials, and to investigate special problems of manufacture, inspection and service use of defence stores and equipment.

With commencement of construction of the Maribyrnong laboratories in 1920, the Munitions Supply scheme thus became launched, but it was not until 1921 that the administrative body recommended in the report, the Munitions Supply Board, was constituted. The membership, was as follows:-

“Chairman: A. E. Leighton, F.I.C., Controller-General Munitions Supply.

“Deputy Chairman: Col. T. J. Thomas, O.B.E., Finance Secretary of the Department of Defence.

“Member: M. M. Maguire, Assistant Secretary of the Department of Defence.

“Secretary: J. K. Jensen.

Munitions Development Plan

Early in 1922 the Government, while giving attention to a general reduction of Defence expenditure, most of which was still connected with the aftermath of the war, was receptive to Army proposals which were aimed at enhancing local Defence capability rather than the stock piling of reserves.

The Munitions Supply Board devised a development plan whereby savings gained by reduction of the manufacturing programme were applied to a new construction programme. The MSB suggested a capital expenditure of £900,000, to be spread over six years, and this, added to some £360,000 which had already been spent on 'surplus' plant purchased in England, building laboratories in Australia, etc., made up a plan to cost £1,116,000. It was endorsed by the Government, but through one cause and another, including later additions to the original scheme, was not completed until 1930.

.As the new laboratories were taking place alongside the 'Cordite Factory" at Maribynong, action had commenced to create :-

- "a new Defence Inspection Organisation,

- “a new high explosive manufacturing capability at the Cordite Factory,
- “a new pistol and machine gun plant at the Small Arms Factory at Lithgow
- “a gun ammunition factory at Footscray adjacent to CAC
- “gun manufacturing and shell forging capability at Maribyrnong.(ie an Ordnance Factory)
- a central administration section at Maribyrnong located between the Ordnance factory and the Laboratories to house the Inspection Headquarters, a Central Drawing Office and Document Control and the Senior staff of the Munitions Organisation.

During 1921, at the request of the Military Board, the initial steps were taken at CAC for the manufacture of 0.455" ammunition for the Webley pistol and experimental work commenced on special 0.303" ammunition (known as “Red Label” or Air Service Ammunition) to be used with machine-guns mounted in aircraft.¹ These initiatives were assisted by the newly constructed Munitions Laboratories and the

1. Reference 3 Annual Report July 1924- June 1925 page 12

Inspection Service. Drawing Y-928 defining the .455 ammunition was prepared by Leighton's staff in January 1921 and a reproduction of this is on the next page.

The first deliveries of .455 ammunition of 665,000 rounds was reported in the 1923-24 Financial Year.² This included 40,000 rounds to the RAN with the balance to Army.

By 1926 the factory was able to report that .303 tracer ammunition had been successfully produced in small quantities and that work was proceeding on the experimental manufacture of .303 Grenade launching cartridges using a charge of 30 grains of Ballistite.³

2. Reference 3 June 1924 Confidential Report Pages 12 & 13

3. Reference 3 July 1924- June 1926 Confidential Report page 14

Gun Ammunition Factory

While the leasing of CAC was continuing, the Defence Department had proceeded with the establishment of a Gun ammunition Factory on land it controlled immediately to the north of CAC and an Ordnance Factory on the former WW1 Royal Australian Field Artillery Depot in Maribynong. Both of these projects were connected to the local manufacture and supply of 18 pdr guns and ammunition. The new Ordnance factory was to manufacture the guns and the shell (projectiles) while the Gun ammunition plant was to make cartridge cases and fuses.

Utilising much of the equipment and plant acquired cheaply from England, construction of fuse and case workshops was initiated with supporting foundry and rolling mills to follow. By June 1926 the case shop was ready to manufacture 18 pdr. Cartridge cases subject to receipt of an annealing furnace from Britain and the fuse shop had about 75% of its machinery installed. The foundry and rolling mill were approved for construction during 1926-1927. The following drawing depicts the general layout of the Gun Factory and its location relative to CAC.

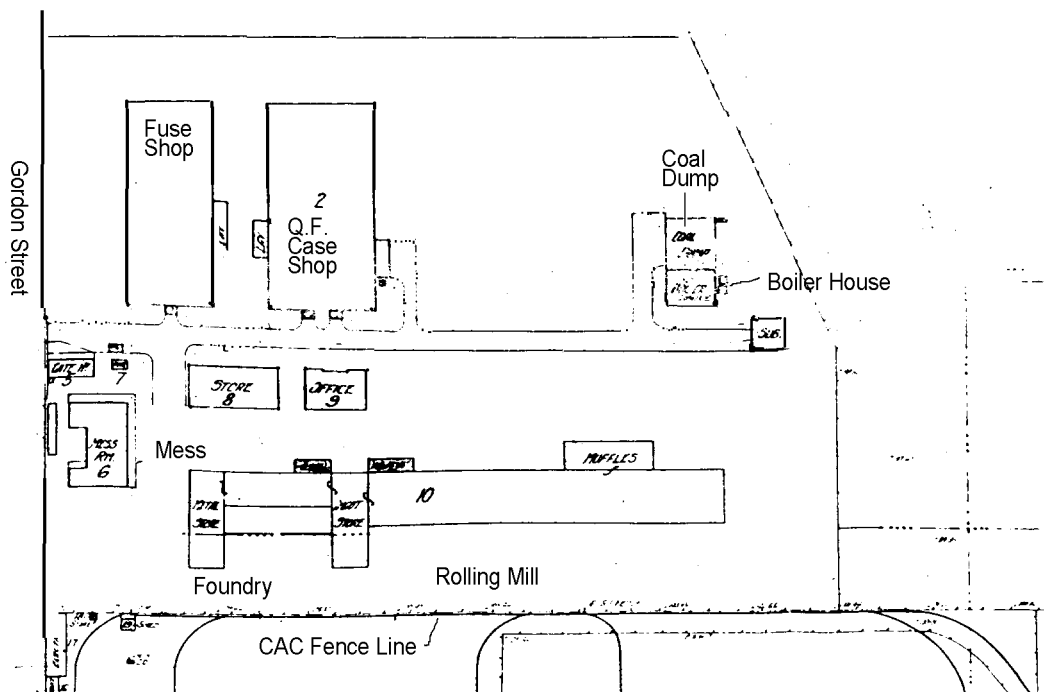

FIGURE 5. *The Footscray Gun Ammunition Factory*

Full ownership of CAC

When the Defence Department finally gained ownership of CAC in 1927 it coincided with the request by the then manager Mr. G.A.Cartright to relinquish his position as from 31st December 1927. Consequently in 1928 the 'CAC' plant was 'merged with the Gun Ammunition Factory under it's manager

Mr. J.H. Wrigley. This brought some duplication in the form of two foundries and two rolling mills. Consequently the older 'CAC' facilities were phased out and decommissioned. In addition, the new Ordnance Factory had wood working facilities suited to the making of ammunition boxes. Consequently the 'box' workshop at the 'CAC' site was closed and its operations transferred to the Ordnance factory.

Delayed Quality Problems.

In the MSB Annual Report for the Period 1927-1929 the Inspection Group reported that investigations were being carried out into a damaged rifle and ammunition at Williamstown, a burst cartridge from a Rifle Club, and burst rifles from Tasmania and Victoria. The outcome was that the problem was attributed to accidental double bulleting of MkVI .303 ammunition at CAC during the peak war time production effort of 1916-1917 when rates of 2 million rounds per week were achieved. A similar investigation some 20 years earlier had concluded that double bulleting was indeed possible. (see chapter 2). Existing stocks of ammunition from this period were ordered to be check weighed to attempt to detect any further potential problems. As ammunition cartons were

weighed and cleared they were stamped with a marking to indicate that the ammunition had been checked.



FIGURE 6. A 'check weighed' ink stamping on a carton of 1917 CAC Mk VI .303 ammunition indicating the ammunition was check weighed in Melbourne 28-12-1930.

Commercial Work

With the diminished orders from the Defence users, each of the Government Factories was encouraged to take on 'Commercial' work. Work which 'displaced' imported goods or supplies was given priority. Work which directly competed with local industry was discouraged. Arising out of complaints from the Associated Chamber of Manufactures the matter of Commonwealth Factories performing commercial work was considered by Federal Cabinet on 14th March 1932 and a

new instruction was issued in effect saying that the factories could only perform work not able to be done by Australian Industry. This did not satisfy the Victorian Chamber of Manufacturers and in June 1933 a writ was served upon the Commonwealth seeking to prevent any goods being made by the Commonwealth factories and supplied to the State of Victoria and other bodies. The issue appeared to be initiated by the Commonwealth Clothing Factory making and selling non-military clothing to non-military customers. The High Court of Victoria referred the matter to the Federal High Court which delivered it's judgement on 23rd May 1935. The judgement acknowledged the need for the Commonwealth to maintain skills within the factories through the maintenance of adequate workload and left the matter of 'commercial' work to the discretion of the Governor-General and the responsible Ministers.

The Ammunition Factory undertook a range of 'commercial' tasks including:-

- Production of a special order of jacked .310 Cadet rifle ammunition for Papua -New Guinea.
- Development and manufacture of .22 rimfire ammunition for Civilian Rifle Clubs through the period 1931 -1935.
- The production of large quantities of drawn brass lipstick 'containers' for the domestic cosmetics industry.

- Production of .32 Auto and .32 Smith and Wesson revolver ammunition for local police, bank security requirements, government department payroll 'minders' and the like.
- Rolling of brass and nonferrous alloy sheet and strip for local metal merchants. This item represented a rapidly growing revenue item as can be seen from the following table. This work was terminated in April 1938 due to the rising demand for Defence requirements.

TABLE 1. Commercial Metal Strip and Plate output from Ammunition factory Footscray^a.

Financial Year	Metal Output (ton)	Value (Pound)
1930-1931	22	3,690
1931-1932	162	25,905
1932-1933	320	50,887
1933-1934	387	59,898
1934-1935	485	70,475
1935-1936	547	74,506
1936-1937	828	114,333
1937-1938	762	107,387

a. Reference 3 July1937-June 1938 Annual Report

Australia moves toward War

Activity on Ammunition output increased markedly in the 1938-39 period as can be seen in the following table which lists .303 production over the period 1926-1939.⁴ The following year production was put on a War footing.

TABLE 2. .303 Ball Production over the period 1926-1939

Year	Quantity Delivered	Year	Quantity Delivered
1925-1926	2,799,360	1933-1934	3,187,152
1926-1927	7,800,096	1934-1935	8,148,336
1927-1928	8,118,244	1935-1936	14,869,936
1928-1929	8,362,109	1936-1937	15,106,264
1929-1930	5,131,600	1937-1938	14,769,432
1930-1931	3,947,587	1938-1939	23,580,368
1931-1932	3,163,856		
1932-1933	2,511,056		

4. Reference 4 Journal No 73 1998.

Chapter 6: *The Wartime SAA factories*

The first Upgrade at Footscray

By the early 1930's the Munitions Supply Board had implemented the 1920's munitions plan. This had given Australia an updated explosives manufacturing capability, an updated small arms factory, new Munitions Laboratories, a new Ordnance factory, a Defence Quality Organisation and central planning and administration. Despite some upgrading of the 'CAC' ammunition factory in the form of new gun calibre cartridge and fuse shop, the small arms ammunition capability was essentially that acquired from CAC . This facility had reached a capacity of approximately 100 million rounds of SAA per annum at the peak of WW1 production in 1917. The

plant which had some buildings dating back to the 1890's was considered to be in less than ideal condition and a fire hazard. In 1934 the Munitions Supply Board proposed that a new modern SAA plant be built on the Footscray site near the Gordon Street boundary which would bring it closer to the foundry and rolling mill and bring certain efficiencies in the movement of product around the site. The modified site plan showing the 'new' case and bullet shop and assembly, loading and packing facilities was signed off by the then Munitions Controller General, Mr. A. Leighton on September 4th 1937. The more modern Footscray plant (ultimately using the identifier MG) and generally referred to as the No2 Factory, would share many of the Footscray facilities such as the foundry and rolling mill and firing and acceptance ranges. It was to be capable of 100 million rounds of SAA per year. The original intention was to close the old CAC 'lower' SAA plant as soon as the new plant came into production. The political situation in Europe however caused abandonment of the closure of the 'lower' factory. The new No.2 plant commenced deliveries early in 1940. Initially it had been decided to change the identification of small arms ammunition at Footscray by using MF1 as the Factory identifier of the original factory and MF2 for the No.2 plant. Some relatively small amount of cartridges were so marked from each plant before

a change was made to use the MG identifier for the No2 plant and revert to MF for the No1 plant. The following graphic of an early 1940 .303 proof round from the No1 plant illustrates the use of the MF1 identifier.



FIGURE 1. An example of the MF1 headstamp used in early 1940 for a short period. The item shown is a .303 proof Mk III round



FIGURE 2. .303 ball headstamps of the No2 SAAF Footscray 'MG' from 1940 to 1948

Hendon S.A. chosen for new SAA plant.

The Munitions Supply Board commenced examining options to increase SAA production in Australia. As a general strategy, any new facilities were as far as practicable, to be kept in the southern states to draw on 'untapped' labour resources. As the uneasy political situation in Europe deteriorated into war, the Munitions Board proposed that a new plant be built at Hendon in South.Australia, and Drawing W2689 dated 10th October 1939, was prepared at the Cen-

tral Drawing Office at Maribyrnong depicting a 'single factory' with supporting storage magazines and proof firing facilities located on a roughly triangular tract of land in the Adelaide suburb of Hendon. The site was bounded by Tapley Hill Road on the west, Gordon Street on the east and Farman Street on the northern boundary. An existing railway line was conveniently located near to the southwest corner of the site. The intention was to construct a plant at Hendon that would produce 100 million rounds of SAA per annum. This site often referred to as the No. 3 Plant, would use the identifier MH.



FIGURE 3. .303 ball headstamps of No 3 SAAF Hendon 'MH' 1940 -1945

Hendon Plant Duplicated

Construction at Hendon commenced almost immediately but by early 1940 it was obvious that even more production was needed and the decision was made to duplicate the Hendon Plant. The additional Hendon Plant again with a planned capacity of 100 million rounds per annum, was to be referred to as the No4 plant and would identify its production with the MJ code. Drawing W2754 dated 21 August 1940 shows two SAA buildings (MH & MJ) side by side separated by a few hundred feet. Records show employment at the Hendon site was nil as at the end of June 1940 rising to 321 by end of October 1940. In a report to the Munitions Board in October 1940, the No3 plant was reported as complete with production commenced. The No4 plant was then reported as being 75% completed. The report also suggests that with both plants operational, employment at Hendon would rise to 2500 of which 80% would be female. This report indicated that Hendon would draw its metal requirements from the new Gun Ammunition Factory being constructed at Finsbury and cordite from the Explosives Factory Salisbury also under construction.



FIGURE 4. .303 ball headstamps of the No4 SAAF Hendon 'MJ' 1941-1944.

Reorganisation of the Munitions Supply Organisation

Meanwhile the organisational arrangements of the Munitions Group was changing as can be seen from the following passage written by Mr. J. K. Jensen :- "In July, 1939, the Department of Supply and Development was formed upon a nucleus provided by transfer from the Department of Defence of our Munitions Supply Board and the Principal Supply Officers Committee, together with the Contracts Board. Mr. Brodribb was included in the transfer, and resumed his appointment as Chairman of the Munitions Supply Board,

while Mr. Leighton (who had officially reached age retirement in 1938 -D.M.) was appointed a consultative member in order that his wide knowledge and wide experience might be retained. We have grown since, however, and whereas then the administrative staff of the Munitions section consisted of 18 people, it now approaches 6000. In July, 1939, we occupied two floors of 83 William street, Melbourne, and now we are located in 28 buildings in Melbourne, four in Sydney, and one in each of the remaining capital cities. We had four Government factories and the Departmental Laboratories, each one fitted with all essential equipment of the highest quality and precision, and there were 24 Armament Annexes being equipped, of which eight had commenced manufacturing. The war opened, therefore. with an organised Department, even though the directing staff may have been almost negligible in number.”¹

Munitions Ministry Created.

Not long after the split from the Defence Department, further massive organisational changes were initiated with a separate Ministry of Munitions being created. The following pas-

1. Reference 1 Page 8.

sage also by J.K.Jensen explains :- “ In .June. 1940, came the great forward move; we were broken off from the Department of Supply and Development and set up as a separate Department of Munitions, with Mr. Essington Lewis as Director-General in charge of the production effort. Mr. Lewis was asked to prepare a plan for a large scale production of munitions, his first steps being to visit the factories and interview departmental officers while regulations were prepared giving him wide powers. Then on one historic night he called together the principal departmental officers and a plan was prepared for the munitions organisation as it stands today - practically unaltered - ample evidence that some very good planning was done on that .June day in 1940.

Eight Directorates were established for the development of commercial industry for munitions production, and we had also the Government Factories organisation which, throughout, has been under the direction of Mr. N. K. S. Brodribb as Chairman of the Board of Factory administration. Mr. A. E. Leighton, former Chairman of the Board, and now a consultative member, was appointed Consultant on Explosives, with particular supervision over commercial chemical production for munitions purposes.

Complementary to the central Directorates, we set up Boards of Area Management in each State, and here probably their respective functions should be explained. The focal point for the whole organisation is the Director-General of Munitions, assisted, as stated already, by the Factory Board for the Government Factories, and by the Directors, for the organisation of commercial industry. The Directors, as will be shown shortly, were given charge of production of certain groups of Munitions, or in some cases, of matters accessory thereto. The Director-General was to be the co-ordinating authority as between the Directors themselves, between the Directors and the Area Boards, and between commercial industry and the Government Factories.”²

Finsbury comes on line to supply Hendon

In August 1941, the Finsbury Gun Ammunition plant was reported as just commencing production. Presumably since production had been underway at Hendon No3 for almost a year, it must have done so with metal supplies from the Footscray Rolling mills and the “Cordite” factory i.e. Explosives

2. Reference 1 Page 9.

Factory Maribyrnong. The Hendon and Finsbury plants were under a single Manager at that time i.e. Mr. W.M.B. Fowler.

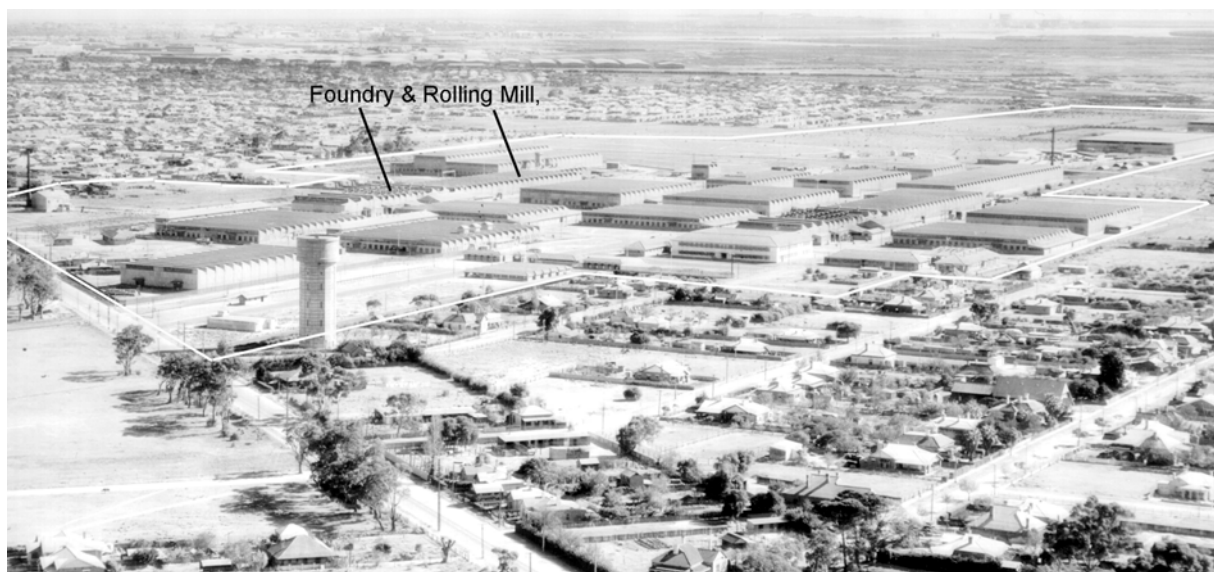

FIGURE 5. The Finsbury plant S.A. circa 1943 as viewed from above Torrens Road looking north-west. The enormous plant covered an area of approx 1.2Km x 0.8Km and provided the metal needs of Hendon and Welshpool SAA plants as well as its own needs as a large calibre case and fuse manufacturer. The feint white line added to the photo indicates the boundary fence line.

Rebuild of Footscray No 1 Plant

By December 1940, total Australian 303 production had reached a rate of 200 million rounds per annum with expectations that a demand of 300 million rounds per annum

would be reached by March 41, 400 million by June 41 and 500 million by September 41. Approval was given to rebuild the No1 site at Footscray and production was moved to a large new SAA building constructed on the river flats area just north of the previous building.

Plants planned for Rocklea and Welshpool

As the estimates exceeded the total planned capacity of the previously mentioned 4 plants, by late '41 the Munitions Ministry had a further 3 plants planned. These were to be Factories No. 5 and 6 to be built at Rocklea, a suburb of Brisbane, and Factory No. 7 to be built at Welshpool a suburb of Perth and each was to be capable of 100 million rounds per year. The choice of the Rocklea site was at variance to earlier stated intentions of keeping plants in the southern states. The logic for this change was not given.

The Rocklea SAA plant which would come to use the MQ identifier was to be built together with a large calibre case shop, in undulating hills about one kilometer east of Rocklea Railway station and about 7km due south of the Brisbane city centre. It straddled Evans road. It was planned that the Rocklea plant would not require foundry or rolling mills and

would draw its metal needs from industry in Sydney and tooling from the Railway Workshops at Ipswich. Detailed drawings for the Rocklea buildings carry dates of May 1941 while those for Welshpool August 1941. Both sites had access to railway facilities via spur lines entering into the factory boundaries.

The 1945 site layout for the Rocklea site which follows, shows only one SAA Building of 138,000 sq. ft. in area and a foundry and rolling mill and Toolroom thereby showing three contradictions to the original plan. The individual Hendon SAA buildings each had 'footprints' of 70,400 sq. ft. as did the single Welshpool SAA plant. Presumably the Board's intention to establish two Rocklea plants was modified to have one large facility of the required capacity. The presence of the foundry, rolling mill and toolroom also suggests a change in plan. The Rocklea site plan also shows a large Case Factory and Machine Shop of 230,000 sq. ft. (for large calibre gun cartridge cases). A photograph of the Rocklea site taken in March 1941 entitled 'Site Preparation' shows most of the Buildings in place. A photograph in the Government Archives shows the first SAA ammunition delivery from the Rocklea plant being made in February 1942.

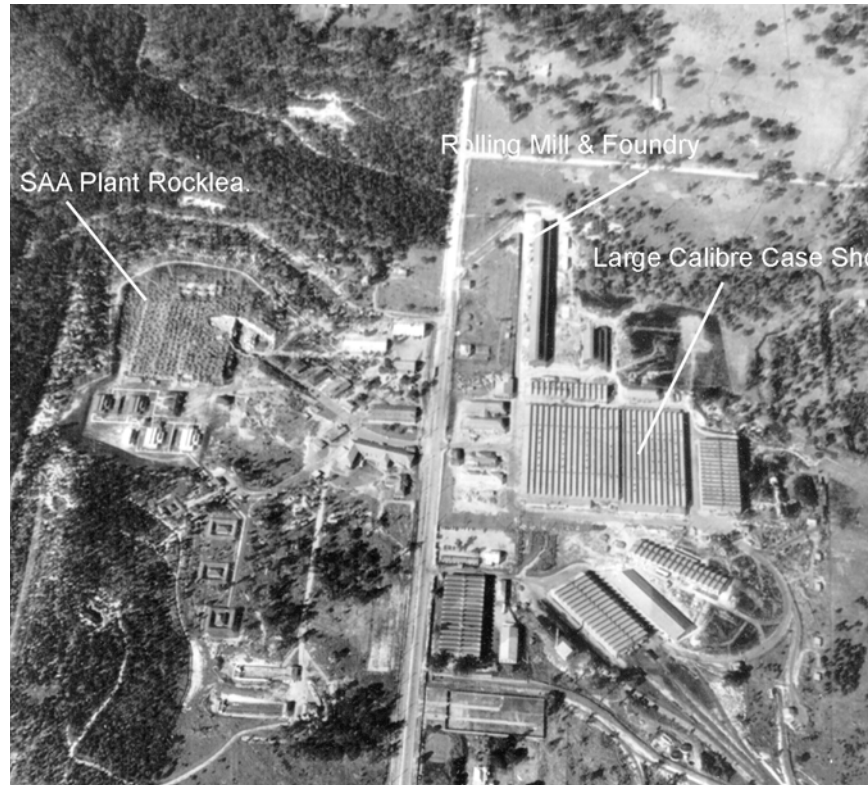

FIGURE 6. An aerial photo of the Rocklea site circa 1945 with the SAA buildings still partly shrouded in camouflage netting.

The Welshpool Plant which used the MW identifier, was to be located on site near the intersection of Welshpool Road and Rutland Avenue adjacent to the South Western Railway line from Perth. The Welshpool plant, in common with the Hendon plants, was to draw its metal needs from the Finsbury plant in South Australia. The Welshpool site layout as at

1945, featured in addition to the standard SAA facilities, a large building of approximately 56,000 sq. ft. designated as a 'Fuse' shop. Production deliveries from Welshpool commenced in June 1942.

By July 1942 the SAA production exceeded revised requirements and on the 6th of July the Minister of Munitions Norman. J. O. Makin, wrote to the Prime Minister John Curtin suggesting that the Footscray and Hendon Plants should reduce from 3 shifts per day to 2 shifts per day with the 'surplus' labour to be absorbed elsewhere, and that the proposed 3rd shifts at Rocklea and Welshpool be deferred indefinitely



FIGURE 7. .303 ball headstamps of SAAF Nos 6&7 Rocklea 'MQ' 1942-1943



FIGURE 8. .303 ball headstamps of SAAF No 7 Welshpool 'MW' 1942-1945

. Makin advised the PM that “ A situation has arisen in connection with the operation of our Small Arms Ammunition Factories regarding which I consider you should be aware. We now have seven factories established each being designed for a nominal production of 100,000,000 rounds annually, but actually the seven factories working 24 hours per day should produce 800,000,000 rounds annually.....The production scheme upon which the factories were planned totalled at one time 1000,000,000 rounds annually, including substantial shipments to Malaya, Netherlands East Indies, New Zealand, Middle East, Eastern Group etc. but for obvious reasons some of these (requirements) have ceased. The cessation of shipments abroad has considerably improved the Australian position, and the reserve

stocks in Australia are now becoming satisfactory, whereas only a few months ago they were not so regarded. “

Makin went on to explain his proposal to reduce activity at the plants and sought advice as to how to handle the potential negative public comment. The Prime Minister replied on the 23rd of July setting out some guidelines for the reduction of ammunition production as determined by the ‘Chiefs of Staff’ of the Armed Forces and some guidance as to the form of the public statement. On the 25th July a press release was issued advising of reductions in certain munition programmes.

At the Footscray site the workforce had peaked in 1941-42 at 9,323, (4,608 of whom were women) , but as a consequence of the ‘1942 cut-back’, the factory was required to make male employees available for military service and 1,100 were subsequently released. Further reductions in demand at Footscray resulted in employee numbers being reduced down to 2,507 by 1944.

The declining demands for SAA resulted in production at the Rocklea Plant being halted in October 1943 and the SAA buildings handed over to the Department of Aircraft Production for use as a repair and overhaul centre for aircraft

engines for the large number of allied aircraft (especially USAF) operated out of Australia's north. The large case shop had at least some of its orders transferred to the Rutherford (NSW) case factory. In its short career the Rocklea plant produced annually 220 million rounds of .303 ammunition, 2 million .455 revolver rounds, 9 million .380 revolver rounds 3 million cartridge cases for 25 pdr and 0.6 million smoke shell .

Site Plans for the WW2 SAA factories.

The following site plans show the general arrangement of each of the wartime SAA plants as they existed in 1945 except for Footscray which is a mid 60's layout. The main change from Footscray's WW2 layout is the addition of a large building in the lower Factory added by the Myer Company for use as a store during their post war lease of this area.

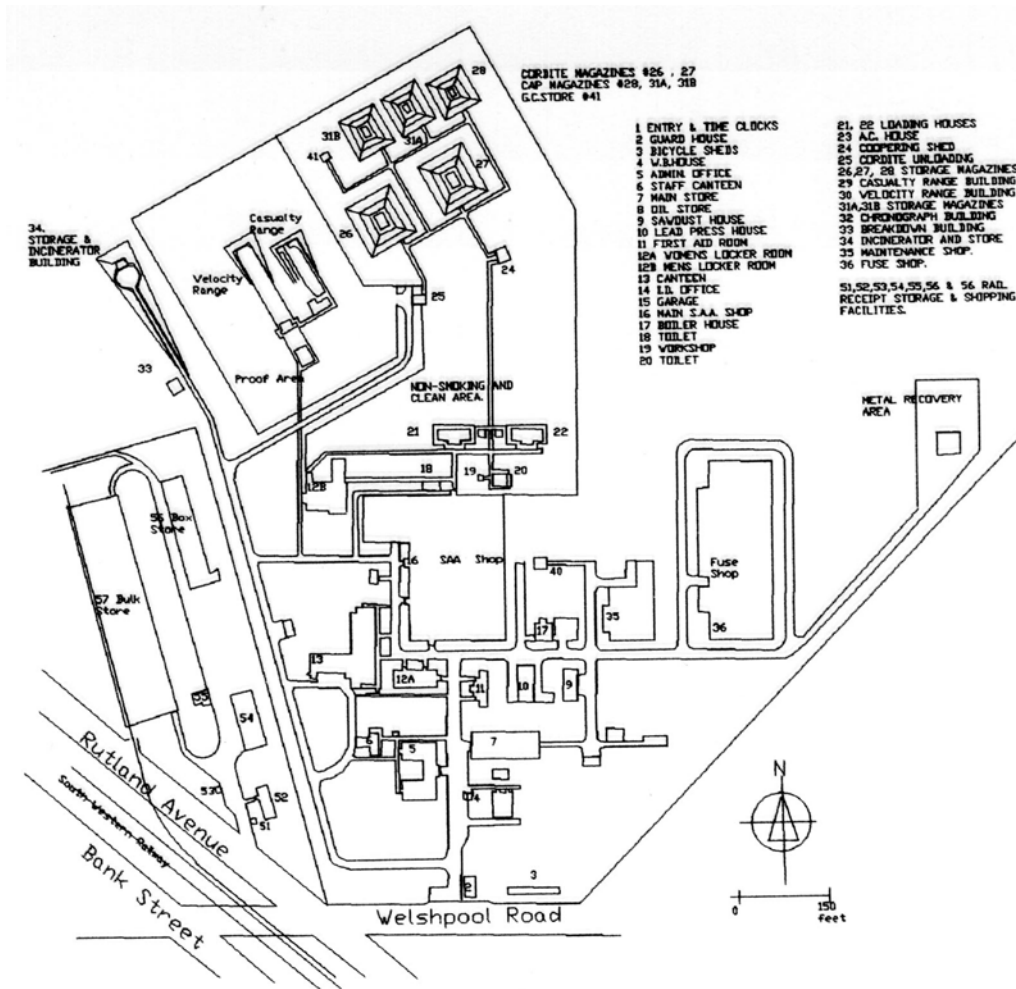

FIGURE 9. Changes to .303 projectile material and crimping: from top cupronickel with neck staking into low cannelure phased out in 1942 to be replaced by gilding metal neck staking which was in turn replaced by mouth coning into a high cannelure in 1944 which continued until cessation of production. The mouth coning of the cupronickel projectile (second from bottom) in 1944 was to use residual 'surplus' cupronickel stock.



FIGURE 10. Bullet retention in Tracer , Incendiary and Armour Piercing cartridges : from top cupronickel and gilding metal tracers with press fit and mouth coning, Blue tipped incendiary with press fit, cupronickel and gilding metal AP rounds with punch neck staking (prior to 1942) and AP with full neck staking

Site Plans for the WW2 SAA factories.



Welshpool SAA Plant W.A.

FIGURE 11. SAA Plant 'MW' at Welshpool W.A. c1945

The Wartime SAA factories

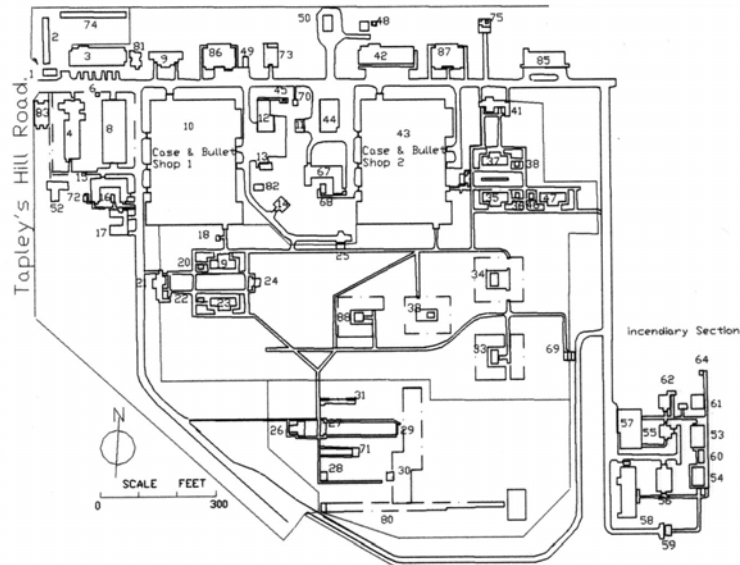

- | | |
|-----------------------------|-----------------------------------|
| 1 GUARD HOUSE | 45 TOILETS |
| 2 BICYCLE SHED | 46 A.C. HOUSE |
| 3 CANTEEN (SEATS 417) | 47 LOADING ROOM |
| 4 ADMIN OFFICE | 48 OUTWORKS STORE & WORKSHOP |
| 5 TIME CLOCKS/ ENTRY | 49 OIL STORE |
| 6 W.B. HOUSE | 50 STAFF MESS |
| 8 MAIN STORE | 51 HEAT TEST HOUSE |
| 9 FIRST AID BUILDING | 52 FILLING HOUSE |
| 10 CASE & BULLET SHOP (MH) | 53 ASSEMBLY BUILDING INCEND |
| 11 GARAGE | 54 |
| 12 BOILER HOUSE | 56 |
| 13 TRANSFORMER BLDG. | 57 CARTRIDGE EXAMINATION |
| 14 BREAKING DOWN HOUSE | 58 CHANGE ROOM & CANTEEN (SEATS 8 |
| 15,16 EXAMINATION BUILDINGS | 59 MAGAZINE |
| 17 INSPECTION OFFICE | 60 A.C. HOUSE |
| 18 WORKSHOP | 61 BULLET EXAMINATION |
| 19 LOADING ROOM | 62 TOILETS |
| 20 A.C. HOUSE | 63 A.C. HOUSE |
| 21 CHANGE ROOM | 64 REJECTED BULLET STORE |
| 22 A.C. HOUSE | 65,66 TIME CLOCKS |
| 23 LOADING ROOM | 69 COOPERING SHED |
| 24 TOILETS | 70 FILTER HOUSE |
| 25 COOPERING SHED | 71 RIFLE RANGE |
| 26 CHRONOGRAPH HOUSE | 72 TOILETS |
| 27 & 28 SHOOTING HOUSES | 73 TECH STAFF OFFICE |
| 29 TARGETS | 74 BICYCLE SHED |
| 30 SAWBUST BUNKER | 75 INCINERATOR & LEAD RECOVERY |
| 31 RIFLE RANGE | 80 INCENDIARY TEST RANGE |
| 32,33,34 STORAGE MAGAZINES | 81 ARP CONTROL |
| 35 LOADING ROOM (M.J) | 82 AUXILIARY POWER HOUSE |
| 36 A.C. HOUSE | 83 FIRST AID/MEDICAL BLDG. |
| 37 LOADING ROOM | 85 CENTRAL KITCHEN |
| 38 A.C. HOUSE | 86&87 WOMENS CHANGE ROOMS |
| 39 WORKSHOP | |
| 40 TOILETS | |
| 41 CHANGE ROOM | |
| 42 CANTEEN (SEATS 417) | |
| 43 CASE & BULLET SHOP (M.J) | |
| 44 LEAD PRESS HOUSE | |

Hendon SAA Plant S.A.

FIGURE 12. SAA Plants 'MH & MJ' at Hendon S.A.

Site Plans for the WW2 SAA factories.

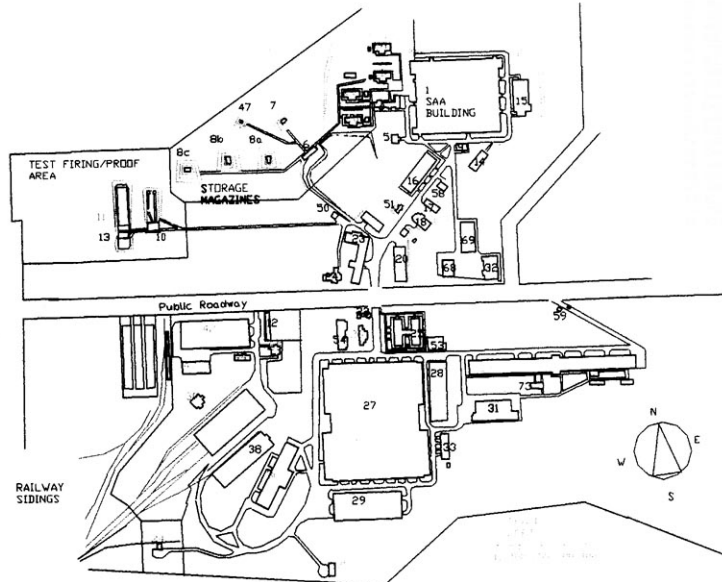

- | | |
|----------------------------------|-----------------------------------|
| 1 SAA BUILDING | 33 MAINTENANCE BUILDING CASE SHOP |
| 2A,2B,2C,2D LOADING ROOMS SAA | 34 UNLOADING BUILDING |
| 4 CHANGE ROOM SAA | 35 DESTROYER |
| 5 BREAKING DOWN HOUSE SAA | 36 MACHINE SHOP |
| 6 COOPERING BUILDING | 37 ROLLING MILL & FOUNDRY |
| 7, 8A,8B,8C,47 MAGAZINE STORAGE | 38 STORE |
| 8 FIRST AID BUILDING | 42 BULK STORE |
| 10 CASUALTY RANGE | 43 GARAGE |
| 11 WELD/CITY RANGE | 44 OFFICE |
| 12 BICYCLE SHED | 45 BULK STORE |
| 13 CHROGRAPH HOUSE | 50 EMERGENCY FIRST AID |
| 14 OFFICE & CANTEEN | 51 WARDEN'S POST |
| 15 INSPECTION BUILDING | 53 ELECTRICAL WORKSHOP |
| 16 CANTEEN | 54 LABORATORY |
| 17 SAW/DUST PREP. BUILDING | 55 CANTEEN |
| 18 LEAD PRESS BUILDING | 58 AUX. BOILER HOUSE |
| 19 | 59 GUARD HOUSE |
| 20 STORE | 69 TRAINING BUILDING |
| 21 | 73 MILL STORE |
| 22 GUARD HOUSE (CASE FACTORY) | 74 FOUNDRY STORE |
| 23 ADMIN OFFICE | 75 METAL STORE |
| 24 STAFF CANTEEN | |
| 25 CANTEEN (CASE FACTORY) | |
| 26 MAIN FIRST AID BUILDING | |
| 27 CASE FACTORY AND MACHINE SHOP | |
| 28 TIDL. ROOM | |
| 29 STORE | |
| 30 BOILER HOUSE | |
| 31 MAINTENANCE BUILDING | |
| 32 CENTRAL KITCHEN | |

FIGURE 13. SAA Plants No 5 & 6, 'MQ' at Rocklea Queensland.

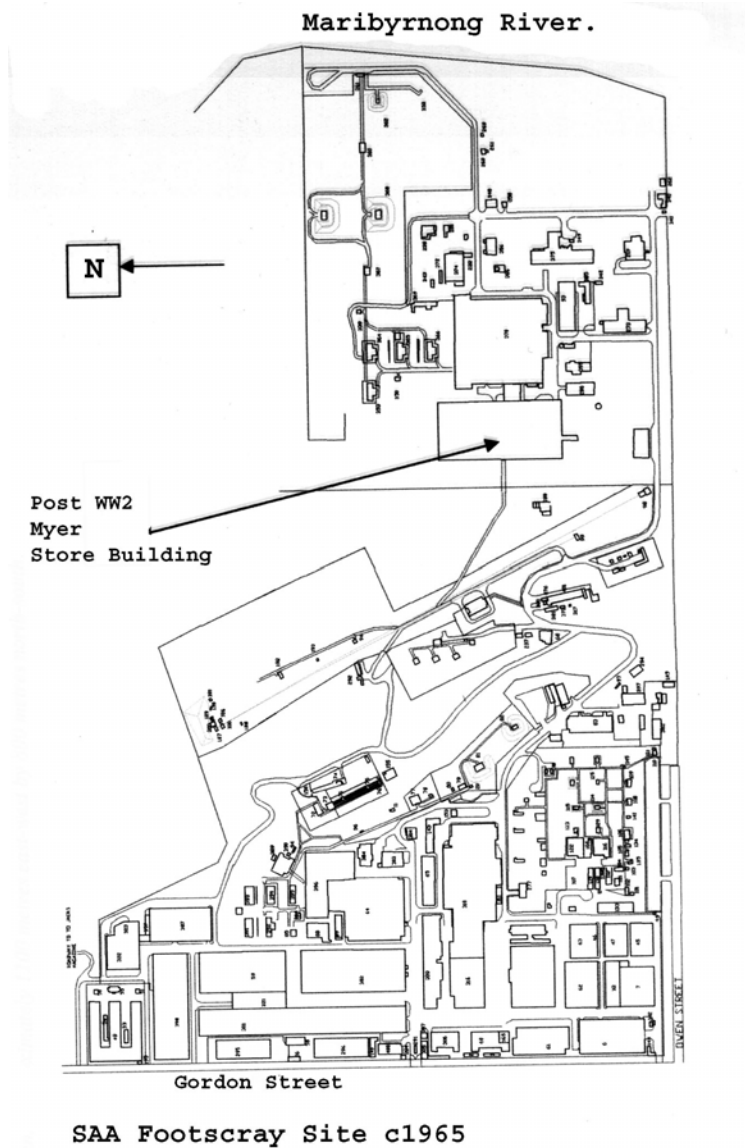

FIGURE 14. SAA Plants 'MF & MG' at Footscray Victoria.

Chapter 7 : *The end of .303 production.*

Closure of Wartime factories,

At the end of WW2, Australia had the production capacity of 500 million rounds of SAA per year. The Rocklea plant with its capacity of 200 million rounds per annum had been closed in 1943 as noted in the previous chapter. The surviving SAA sites included two at Footscray in Victoria , two at Hendon in South Australia and the Welshpool plant in Western Australia. The large reserves of .303 and other ammunition on hand at the end of the war left no option but to immediately scale back production. Consequently all but the Footscray No2 plant (MG) were closed by the end of 1945.

As noted earlier, the original intention of building the No2 plant at Footscray was to bring the SAA operations away from the river flats area and place it closer to the supporting operations of foundry and rolling mill and the like. So even though the No1 Factory had been upgraded and expanded during the war it was marked for closure. Ultimately the No1 site was leased to the Myer retail organisation and the site was used for storage and some furniture manufacturing operations. The buildings were cleared prior to the lease with much equipment joining that from Rocklea, Welshpool and Hendon in the Government Disposals System. Myer erected a 'new' large warehouse alongside the No1 SAA building to increase floor space.

A good cross section of the surplus equipment was acquired by Mr. George Lansell who set up Super Cartridge Company at 151 Rayleigh Road Maribyrnong. It is interesting to note that on the eventual closure of Super Cartridge Company in the 80's some of this surplus war time equipment was still stored there as it was taken from the war time factories. Many of the machines still had wartime components in the feed hoppers.

Limited post war production of .303 ammunition.

Limited production of .303 ammunition continued at Footscray through 1946 to 1948 using the No2 plant identifier MG. Production of 9mm, .45Auto and .380 revolver ammunition was suspended until further notice. Employee numbers at the Footscray site had fallen below 1000 in 1948.

In 1948 The Munitions Ministry was 'absorbed' back into the Department of Supply together with elements of the Department of Aircraft Production.

In 1949 a decision was made at the Ammunition Factory Footscray to revert to the identifier MF for all subsequent SAA production. Production of .303 ramped upward during the Korean conflict and was maintained at reasonable levels to support Civilian Rifle Clubs usage, Military Cadet activities and National Service consumption.

The manufacture of charger clips for .303 which had been centred at the Ordnance Factory Maribyrnong since the 30's was discontinued in favour of ongoing production at the Ordnance Factory Bendigo. Bendigo product carried the 'BO' identifier and later 'MBO'.



FIGURE 1. .303 Chargers: At the top a Mk IV made by MO (Maribyrnong Ordnance), with a drab olive and conventional black phosphated Mk 4 made at BO (Bendigo Ordnance)

During the early 50's the Defence Department was seeking to replace the .303 weapons with a new suite of weapons taking the new ammunition standardised across the NATO members. Although Australia was not a member of NATO it followed the USA and UK in adopting the 7.62mm x 51 ammunition. Australia chose the Belgian FN designed Self Loading rifle as the individual weapon and the United States M60 machine gun as the standard Army machine gun.

The last production runs of .303

Preparations were made to commence production of 7.62 ball ammunition at Footscray. New cartridge manufacturing machinery was ordered from France and initial production got under way in 1956 in parallel with the .303 production lines.

The last production runs of .303

The last regular production of .303 ball and blank loadings ceased in 1960 however a special order for a quantity of .303 ball for the Cadet organisation was processed in 1962. Unfortunately the Cadet requirement was badly under estimated and subsequently imported English (Kynoch ICI) Mark 7 then Indian Mark 7 from the Kirkee Ammunition Factory was acquired for the Cadet movement. Much of the Indian ammunition was repacked by the Footscray factory in the late 60's and early 70's. Charger loaded Indian stocks were covered with a grease like material and at Footscray the rounds were 'de-clipped' and rumbled in sawdust to remove the 'grease' prior to repacking in cardboard packets of 48.

Cadet rifle training eventually became 'politically incorrect' and the .303 rifles and ammunition were withdrawn.

The end of .303 production.

Chapter 8: *Manufacture of 7.62 x 51 ammunition*

Commencement of 7.62 production

The first Australian production of the 7.62 round took place in 1956 at the Ammunition Factory Footscray. The British System of type marking was used on this ammunition and the first ammunition carried a designation of L2A1. This short lived pattern was replaced by the L2A2 in 1957. Production rate increased over subsequent years as the new weapons were distributed to the Defence Forces and the .303 weapons and ammunition were phased out.

Ball rounds and inspection rounds were produced in 1956 followed by fluted drill rounds, Inspection rounds, proof and grenade launching rounds in 1959. Footscray also made ballistic standard rounds for its own internal needs. A European designed full length 'plastic' blank with metal head insert was put into 'licensed' production in 1961 designated L1A1

The NATO symbol

In 1960 Footscray included the 'NATO'  symbol into the headstamp for the ball round. The Footscray plant was subsequently advised that the NATO symbol could only be included into the headstamp if the ammunition was independently tested and verified to fully conform to the NATO specification by one of the overseas approved testing authorities. The symbol was dropped from the headstamp part way through 1962. Subsequently several batches of ammunition were submitted overseas for test at considerable expense but 'the Defence System' was not committed to this concept and the quest for NATO approval was eventually dropped.



FIGURE 1. 7.62 Ball round headstamps 1959 through 1963 showing introduction then deletion of the NATO symbol .

The 7.62 ammunition was placed into maximum production in the late 1960's as the USA purchased considerable stocks of Australian Defence Reserve ammunition to support its operations in Vietnam and the Footscray factory was given additional replenishment orders.

The 'new' ammunition required new charger clips for the rifle and disintegrating links for the M60 machine gun. These were put into production at the Bendigo Ordnance facility. The links for the M60 machine gun were the USA designed M13 link. The chargers for the rifle were of a 'mauser style'. Both were black phosphated steel.



FIGURE 2. From top : 50 browning M9 link circa 1980's , 7.62 charger made in 1964 and the 7.62 M13 link for the M60 machine gun made at Ordnance Factory Bendigo and carrying the MBO mark.



FIGURE 3. The 5 round 7.62 charger with black phosphated steel body and spring steel inner platform made at Ordnance Factory Bendigo from the early 60's.

Problems with pressure.

The Australian Army converted a quantity of otherwise surplus .303 BREN light machine guns to 7.62 calibre. This was quite a reasonable idea since the original weapon design was for the similar rimless 7.92 Mauser cartridge. Consequently these weapons were then included in the 'casualty' firing acceptance at the factory. Cartridge failures began to occur

with certain of the tests particularly the 'hot' test with the Bren. This problem led to a detailed study of the cartridge case internal geometry and the propellant (AR2201) characteristics at high temperature. Part of the findings included a discovery that due to 'toolmaking liberties' in the cartridge drawing and forming tools, certain case dimensions had moved progressively toward low tolerance (i.e. minimum metal condition). This caused considerable embarrassment for the Factory and steps were taken to remedy the situation. An improved propellant (AR2206) was also introduced. The resultant round was designated as F4 and 1979 dated rounds carried this marking with the L2A2 marking ceasing in 1978.

The original Munitions Supply Laboratories had been renamed years earlier as 'Defence Standards laboratories'. Whereas these laboratories were initiated as a support to the munitions industry with expertise in metrology, materials, gauge design etc., the years had seen their activities move across Defence matters generally. In the 70's these laboratories announced that they would no longer participate in industry support as such, and would concentrate on research. Consequently their metrology and gauge design section was disbanded.

Ammunition Factory Footscray picked up most of the Metrology role of the laboratories and became the prime metrology centre in Victoria.

Commercial Ammunition and Components

The 70's saw Footscray trying to supplement the diminishing defence workload by (once again) turning to commercial work. The Gun cartridge presses were used to make a variety of items including 'drawn' pressure cooker saucepans and components for domestic stoves. The SAA section developed a range of components for sporting shooters. This included Boxer primed cases for .223 Winchester (5.56mm), .243 Winchester, .308 Winchester, 30-06, 9mm and .38 Special. Tin coated lead projectiles were also made in .38 calibre and .45 calibre. The pistol cases and projectiles were aimed at local pistol clubs while the rifle cases were on sold to customers such as Super Cartridge Company which in turn loaded the cases and then sold the ammunition under their own trade name. One large consignment of .223 Winchester was sold to a distributor in the USA. A quantity of .308 was loaded and sold directly from the Factory.



FIGURE 4. Commercial .308 produced by Footscray including loaded rounds (two top items) with headstamp MF 308 ; primed boxer cases with no headstamp (lower left) and bearing 308 only (lower right)



FIGURE 5. Some commercial handgun projectiles : from left .45 tinned lead projectile, .38 tinned lead wad cutter and jacketed .38 projectile.



FIGURE 6. .38 Special revolver cases : the top example carrying MFC (Commercial) identification the lower carrying MF only.

The Factory also supplied ammunition against 'non-military' orders particularly for the State and Territory Government departments responsible for eradication of feral animals. In the Northern Territory and Western Australia, eradication programmes were mounted against buffaloes, wild camels and donkeys. In some of the programmes helicopters were used with marksmen equipped with military self loading rifles. Initially military 7.62 ammunition was supplied but success was less than desirable because of the 'stiff' 144 grain full metal jacketed projectiles wounding rather than killing the animals. This situation lead to the Factory loading soft pointed and hollow pointed bullets and also heavier (170 grain) full metal

jacket projectiles in the ammunition supplied for these programmes.



FIGURE 7. Commercial Rifle Cases : from left 30-06, 308W, .243W (loaded by Super Cartridge Company) and .223W loaded at the Factory



FIGURE 8. Headstamps of Commercial Rifle cases : from left 30-06, 308 W and 243 W



FIGURE 9. Commercial .223 W (5.56) of the 70's headstamped MFC compared to Military 5.56 of 1988



FIGURE 10. Non military 7.62 projectiles from top 170grain FMJ , 150 Grain soft point and hollow point.



FIGURE 11. Non-military 7.62 loads of the early 1990's from top 1990 full metal jacket 170 grain boat tail bullet, 1993 and 1991 hollow points, a 1991 soft point and an undated soft point.



FIGURE 12. Animal eradication soft point loads circa 1985

Chapter 9: *The New 5.56 ammunition and
the end of AFF.*

Changing Government Plans

The post war Department of Supply was broken up in the 70's with the Laboratories moving back to Defence. The Factories were 'moved' through a range of new Government Departments, including Manufacturing Industry, Industry and Commerce, Department of Productivity and Defence Support. They became the 'test beds' for Government labour experiments such as 'industrial democracy'. They also became more and more remote from their customers. The factories were controlled by a remote Canberra head office bureaucracy. Successive Federal Governments were preoc-

cupied with other issues and there was no long term vision for defence manufacturing. With little or no perceived threat to Australia, Defence generally was 'on hold' and Defence Industry and the Government Factories had no clear future.

A New 5.56 Calibre and Weapons system.

Following moves by the NATO alliance to adopt a small calibre weapons system to replace the aging 7.62 weapons, the Australian Defence Department announced its intention to follow the NATO choice of a smaller calibre. After a series of Trials, NATO adopted the 5.56x45 calibre. The ammunition type chosen was the FN SS109 cartridge. This round featured a 4 gram (62 grain) projectile with a composite core comprising a hardened steel penetrator and lead slug enclosed in a gilding metal jacket. A muzzle velocity of 905 metres per second was achieved in the ballistics barrel fitted with "Kistler" type 6203 pressure transducers. NATO subsequently changed to type 6215 transducers and the barrel equipped in this manner produces a velocity approximately 10 metres per second faster.

The USA designated their round the M855 ball. The Footscray manufactured equivalent would eventually be known as F1 ball.

There was no agreement by the NATO allies as to common weapons and a number of the NATO partners chose their own locally made designs. This left the Australian Defence Department with the problem of choosing suitable weapons.

With the announcement of the choice of the 5.56 calibre, Winchester Australia a subsidiary of the large American Ammunition maker, lobbied the Australian Government to have the new ammunition made in their plant at Geelong in Victoria, as they had access to all of the necessary 'know-how' from their parent company. One of the key arguments was that double base propellant such as that made by Winchester, was essential to achieve the specified ballistics in the 5.56 ammunition, and Mulwala, the only surviving propellant manufacturing site was set up for single base (nitrocellulose) propellant. To their credit, the technical staff at Mulwala achieved what was thought impossible by developing a new single base propellant that could achieve the requirements of this new ammunition. Despite the lobbying, the Government tasked the Ammunition Factory Footscray

with supplying the new ammunition. Following consultation between Mulwala and Footscray, the initial production difficulties experienced with leakage of gas around the primer/case interface when fired from the F89 Minimi weapon at low temperature when the cartridge was covered with ice or when wet, were overcome by reducing the primer firehole from 2mm diameter to 1.8mm diameter.

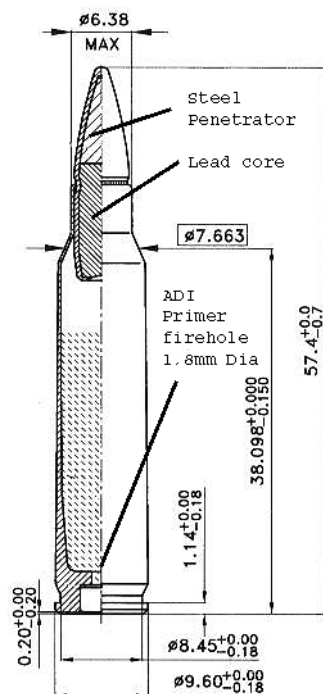

FIGURE 1. The arrangement of the FN SS109 5.56x45 cartridge noting the ADI modification to the primer firehole.

Through the 80's the Army was evaluating the range of 'contender' weapons in 5.56 calibre eventually choosing the Steyr F88 rifle as the individual weapon (IW) and the FN F89 Mini-mi as the light support weapon (LSW).

Browning 50 calibre machine gun ammunition.

Even though the Australian Defence forces had been using 50 calibre ammunition since WW2, manufacture was not initiated until the 80's. WW2 aircraft of USA origin were often equipped with 50 Brownings as were certain Army fighting vehicles supplied from the USA. While the 50 Browning vanished from post war aircraft, the Army retained the weapon as a heavy machine gun. The Navy introduced 50 brownings as 'removable' deck mounted guns on their Patrol Boats. The reason for the delay in local manufacture is unclear but the commencement of production in the 80's may have been made to supplement the diminishing workload at Footscray. Ball rounds were made for the services and some inert rounds were made up for internal purposes such as checking the M9 links made at the Ordnance Factory Bendigo.



FIGURE 2. Belted 50 Browning ammunition of late 80's manufacture exhibited at AIDEX, the Australian Industry Defence Exhibition in the early 90's



FIGURE 3. Top a 1988 50 Browning specimen headstamped with the AFF identifier and below an inert specimen with blind primer pocket dated 1985 and used at Ordnance Factory Bendigo during setting up the M9 link programme/

Gulf and Western Plant

The USA ammunition makers had been using automated plant to make their ammunition including 5.56 calibre for many years. After an overseas fact finding tour by Factory, Defence Quality and Purchasing representatives in 1983, the Footscray factory sought and obtained approval to obtain such plant to enable it to maintain competitive productivity and pricing. The Factory placed orders for a new 'high speed automated cartridge plant to be supplied by ADEC a division of the Gulf and Western company of the USA.



FIGURE 4. A View of the G+W plant from the operators console with the cartridge conveyor and tooling system behind the screens (from an AFF brochure)

The plant was installed and ready for trials in 1985 and a range of 7.62 cases were produced on this plant. The intention was to have universal 7.62 cases and subsequently 5.56 cases (i.e. without type markings) so cases made on this equipment carried only the factory identifier and the last two digits of the year of manufacture. This plant also was designed around boxer primed cases and consequently the factory introduced boxer primers for 'Gulf cases'. 'Dots' appeared in the headstamp between the Factory identifier and date markings to assist in identification of cartridge cases produced from a particular tool station in the 12 station 600 parts per minute machine. (see following figure)



FIGURE 5. Gulf and Western Plant made 7.62 cases 1985-1988: Note the boxer primer configuration and the change of headstamp to AFF in 1988.

Limited quantities of 7.62 cases were made in 1985 through to 1988 while the berdan primed F4 7.62 cases continued in production on the conventional machines. The conventional machines were ultimately converted to manufacture boxer type cases. G+W cases can be positively identified from those made on conventional plant by examination of the internal surface of the cartridge head. During cutting of the extractor groove on the G+W machine, the case head was supported on a mandrel which had 'gripping' teeth to prevent

case rotation. G+W cases display such impressions on the inside of the case head.

Footscray's Centenary

In November 1987, the factory made a special batch of ammunition for use in the International 'Palma Match Competition' which was to be held in Sydney in March 1988. The cartridges were made on the conventional plant (berdan primed) and carried a special headstamp. These rounds were issued in a variety of forms including clear plastic 'film packs' and a commemorative 20 round packet (figures 6 and 7).

The Factory also celebrated its 100th anniversary in 1988 and issued a commemorative batch of ammunition for the Civilian Rifle Clubs and others. This ammunition also carried a special headstamp and could be obtained in an attractive 20 round packet somewhat similar to the 'Palma' one. Figures 8 and 10 show this packet. It should be noted that an error occurred in the 'short history' of AFF which was printed on the rear of this packet (Fig 10) in that it refers to Major John Whitney as the factory founder instead of Captain John Whitney.



FIGURE 6. The front view of a twenty round packet of 'Palma Match' ammunition.

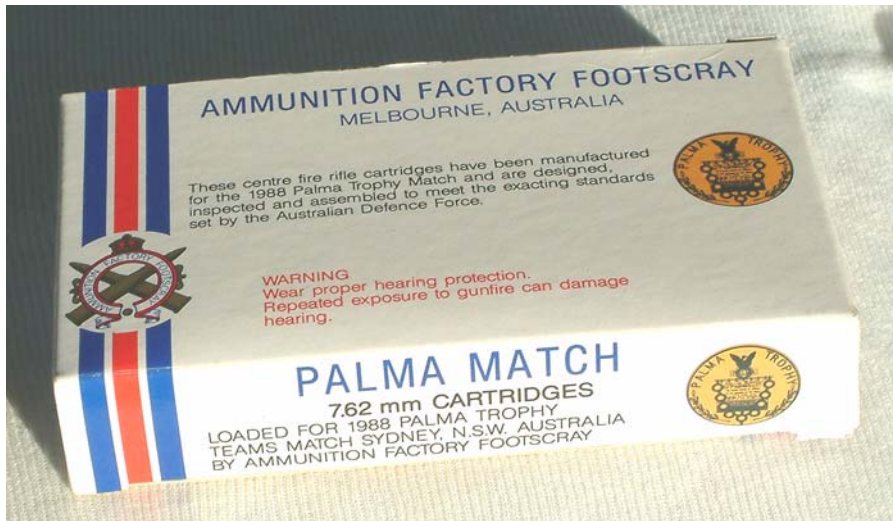

FIGURE 7. The rear and bottom panel of the 'Palma Match' packaging.

Employees were given a booklet including a short history of the factory and featuring photographs of all management and staff employed at that time. The booklet included a special medallion minted for the occasion. (figure 11)

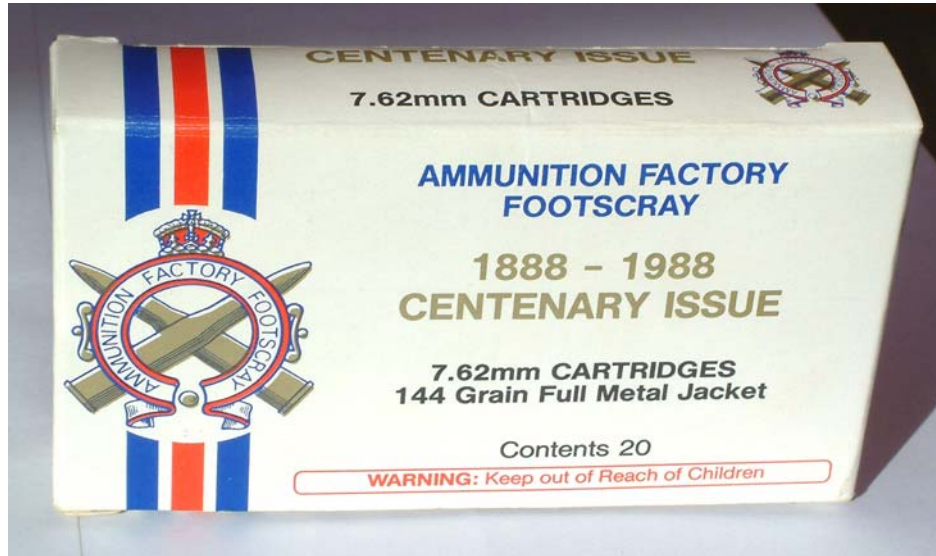

FIGURE 8. Front view of the 'Centenary Packet'



FIGURE 9. Headstamps of the Centenary and Palma Match 7.62 rounds also showing Berdan priming.



FIGURE 10. Rear view of the 'Centenary packet'



FIGURE 11. The Centenary medallion issued to employees rear (left) and front view (right)

The Gulf and Western Plant was designed for high speed continuous production with quick change modular tooling. The compromises necessary to gain this high rate of production from a single machine, included long and flimsy tool modules and complex part transfer systems. The operating efficiency obtained from the equipment rarely exceeded 50% while conventional machines consistently achieved 80%. Tool costs were around three times those required for conventional machines. Benchmarking against International users of similar integrated lines, confirmed that the Footscray plant was being operated close to “Worlds Best practice”.

Australian Defence Industries.

The Commonwealth Government began the process of ‘privatising’ defence industry when in the mid 80’s it disposed of the Williamstown Naval Dockyard to a private buyer. All personnel were retrenched and those employees required by the new owner were offered employment.

This was followed in August 1987 by the established of ‘Aerospace Technologies’ a fully Government owned company from the Government Aircraft Factories (GAF) . This was handled differently to the dockyard in that only certain

employees were retrenched and the balance 'transferred' to the new organisation.

On the 3rd May 1989 the Commonwealth Government placed the control of the Department of Defence Support munitions and certain other establishments under the control of a new fully Government owned company 'Australian Defence Industries'. The creation of ADI followed the 'GAF' pattern in that it commenced with a round of retrenchments to remove excess personnel from the sites, the balance of personnel being transferred to ADI. The top management of the new company had been given a direction to rationalise and streamline the operations of the munitions group and to operate on commercial principles. The new executive devised a plan to rationalise and condense the activities of the existing sprawling sites which essentially occupied the same space as during the operations of WW2.

Site Closures

In 1991 the rationalisation plan was announced surprising and shocking the site managers and employees. The result of ADI's analysis was that Ammunition Factory Footscray was marked for closure along with Ordnance Factory Mariby-

rnong, the Rocket Motor facility in Salisbury South Australia and St. Mary's Filling Factory NSW. A totally new site would be chosen for ammunition production and the necessary elements of SAA production, shell forging and machining, gun cartridge and fuse manufacture and filling of ammunition would be established in a logical layout. Floor space was planned for Fuze manufacture in the new plant but the commencement of fuze manufacture was not planned to commence in the foreseeable future. Of course one of the unstated reasons for the closures, was to start with a green-field site where work practices and attitudes could be developed without the restrictive union and public service traditions of the existing sites. The land value of the closing sites was expected to exceed the cost of establishing the new facility (\$120 Million)

Each site was given a closure date (OFM December 1993, AFF early 1994 etc.). In the time remaining to closure, each site had to complete its current orders and provide bridging stocks of components for the new factory which would bring products on line progressively after the 'old' sites had closed.



FIGURE 12. The change in headstamp from AFF to ADI occurred in 1992 on 7.62 rounds.

Problems with 5.56 Ammunition

As the AFF site was nearing closure, some problems were experienced by the Army with the AFF produced 5.56 ammunition. More than a dozen incidents of 'bullet in bore' had been reported by the Army. A round without propellant does not have enough energy in the primer to eject the projectile into the barrel however propellant fills below a certain amount can lead to projectiles entering but not exiting the barrel. This was a serious issue as not only did it render a soldier's weapon inoperable it also presented a risk of injury to users of the F88 Austeyr IW in the circumstance where (Instant Action Procedure) a user attempts to reload and fire a subsequent cartridge.

A subsequent investigation resolved that all 5.56mm F1 ball cartridges (70 million) be withdrawn from service and examined for correct charge. This examination was conducted by unpacking and using high speed checkweighers in the first instance. With the assistance of the University of Melbourne Physics Department, ADI developed automatic inspection equipment that used gamma rays to examine the propellant fill level in the packaged (Link Belt or Charger) ammunition. This examination revealed a defect rate of one cartridge in 800,000 with insufficient charge to cause the bullet to exit the barrel

The cartridge assembly machine used to load the 5.56mm cartridges at AFF was hand fed with propellant. The machine dispensed this propellant by volume and dropped a probe onto the propellant column at the next station. The position of this probe was required to be measured by the machine and cartridges containing a column plus or minus 3mm from the set height were required to be ejected while the machine continued to run. As a final confirmation that defectives were not being produced one in five cartridges were diverted by the machine from its output stream and passed over a checkweigher. Low charge cartridges were ejected from the checkweigher calling the operator's attention to the fault condition.

The defect had been produced due to a combination of factors :-

1. The machines were fed with propellant by hand. It was possible for the machine to run without propellant;
2. The propellant column height probes were prevented from falling excessively (and damaging the height sensor) by a cam. If the cam and sensor were set incorrectly or adjusted after setting (setting included passing empty cases through the machine and observing them being ejected) or the electronics suffered "drift" it was possible for the cam to prevent a no-propellant cartridge from being identified as defective
3. Ejection of defective cartridges by the checkweighers required the operators to verify the reason for ejection and take corrective action. Corrective action may not have occurred

ADI Benalla

When the intention to establish a new factory was made public a number of the State Governments and Local Government Authorities made representations to ADI seeking to have the factory in their locality. In 1992, ADI selected

Benalla in Victoria as the new site . Benalla had the advantage of being close to the Explosives Plant at Mulwala thus minimising the problem of hazardous transportation of explosives. Footscray closed in 1994 and the site was progressively cleared of buildings and industrial contamination.



FIGURE 13. The Benalla site Circa 2003 set in rural surroundings north of the Benalla township. The main plant is in the foreground with magazines and other facilities in the background.

The new site had recruited around twenty of the Footscray workers to assist in moving, installing and commissioning SAA facilities.

To assist planning the new facility, ADI negotiated a "long term agreement" (LTA) applicable over the forthcoming 20 years, to supply a defined range of ammunition after which it would have to compete openly with overseas suppliers. The Small Arms Ammunition portion of the contract required ADI to install and operate a single shift capability of 24 million rounds per annum (5.56mm or 7.62mm).

Given this requirement the suitability of the Gulf and Western plant was reviewed against the AFF and overseas experience. It was clear that significant cost and quality advantages were presented by traditional "conventional" machines. During the benchmarking tour of international manufacturers a complete production line of mid 1970's equipment was located in Switzerland. These "NOBS" machines were refurbished and formed the basis of the line installed at Benalla. Subsequent production has vindicated this decision with costs running around two thirds of those associated with the Gulf and Western machine.

The Gulf and Western machine had a theoretical single shift capability of 62 million per annum and a proven capability of around 27 million. The Small Arms Ammunition facility was the first to be installed and commissioned on the Benalla site.

Machines commenced installation in late September 1994 and first deliveries were made in April 1996. By the end of the 1995 / 96 financial year over 10 million rounds of 5.56mm Ball ammunition had been delivered from the Benalla facility.



FIGURE 14. The Benalla capping section showing the typical modern facilities and layout of the factory generally

Requirements have continued to grow with annual orders and deliveries averaging 30 million 5.56mm cartridges by 2003. The 0.50cal capability, originally not planned to be installed

until 2005, commenced deliveries in 2001 and is now capable of 2 million cartridges per annum single shift. The benefits of acquiring used equipment have also been applied to the 0.50cal line where plant from a closed Italian factory has been purchased and installed.

The commercial pricing pressure on ADI also resulted in certain supplies and / or components being obtained outside the company.

For example, no foundry or rolling mill was built at Benalla and brass stocks are consequently sourced from overseas as no Australian manufacturer is prepared to make the necessary investment. Primers are imported complete as the cost of metal parts would exceed the total cost of the item. However facilities are available for manufacture of primers, including their explosive constituents, at Benalla.

Sale of ADI

By the year 1998, ADI had been restructured to the point where the owner (the Australian Government) believed ADI was an attractive proposition for purchase by private enterprise. This was consistent with the unstated "second phase"

of the plan commenced with the establishment of ADI in 1989. That is, shedding of Government involvement with Defence manufacturing as had occurred in the UK and other OECD countries. In June 1998 'expressions of interest' for the purchase of ADI were invited. In November 1999 Transfield Holdings and Thomson CSF assumed ownership and full operational control of ADI Limited.

The changing world political scene in 2001 through 2003 (conflicts in East Timor, Afghanistan, Iraq) resulted in the Australian Defence Department foreshadowing requirements for in the order of 50 million cartridges per annum, more than twice Benalla's design capacity.

Equipment for 9mm production was not installed (plant had been brought from Footscray) by agreement with Defence who preferred the funds be directed to a larger medium calibre capability. Conversion equipment and rapid changeover is available for manufacture of 7.62mm Ball if required.

By 2003, ADI offered only 5.56 F1 Ball and F3 Blank, and 50 Cal F1 Ball ammunition with 50 Cal Blank in development.

History Repeats Itself

In 115 years Australia has come full circle with SAA capability. From having nothing before 1888, to limited assembly capability in the early CAC days, and reliance on imported content through to 1910 to self sufficiency by the end of WW1. This was followed by a phase of expansion of capability through the 1920's ,1930's and WW2. Then post war contraction, loss of direction as the Public Service system pervaded the government factories together with fragmentation as the factories were shunted through a range of Government Ministries. Then 'privatisation' stripped the factories of all but essential profit making capability. We are thus approaching the original CAC scenario of a privately owned organisation undertaking limited ammunition manufacturing and assembly activities, delivering against a long term Government contract.

The Government factories and establishments had been over the years, a training ground for thousands of personnel, giving apprentices, tradesmen , technicians and engineers the opportunity to experience a diverse range of manufacturing processes and technologies. Many of these personnel took their training and knowledge into local industry spreading the

benefits of the leading edge technology and quality systems that they had experienced in Government Factories such as Ammunition Factory Footscray. Sadly these opportunities will be severely diminished or unavailable to future Australians



FIGURE 15. Current ADI production of 5.56mm F1 in 900 round package containing ‘film packs’ .

Chapter 10: *CAC Martini -Henry paper wrapped packets.*

Images of Martini Henry Packets

CAC's first production of Martini Henry ammunition for the Colony of Victoria in 1890 consisted of bundles of 10 rounds packed in a thick paper wrapper tied with string. In subsequent years CAC delivered to other Australian Colonies and in at least one instance to New Zealand. Some of these wrappers are shown in the following photographs.

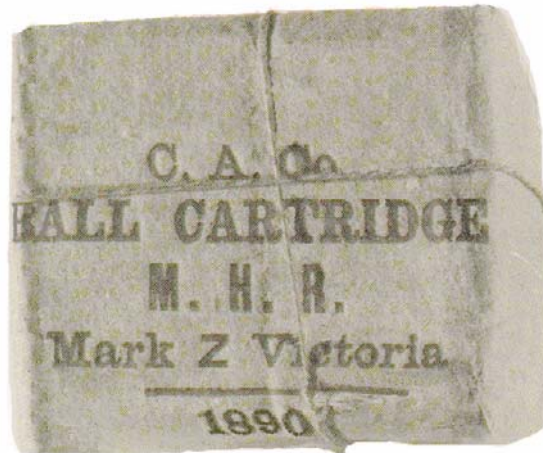

FIGURE 1. A 1890 Mark Z packet made for the Colony of Victoria.



FIGURE 2. A 1892 Mark A packet



FIGURE 3. A 1894 Mark X packet.



FIGURE 4. A 1895 Mark X Packet.
